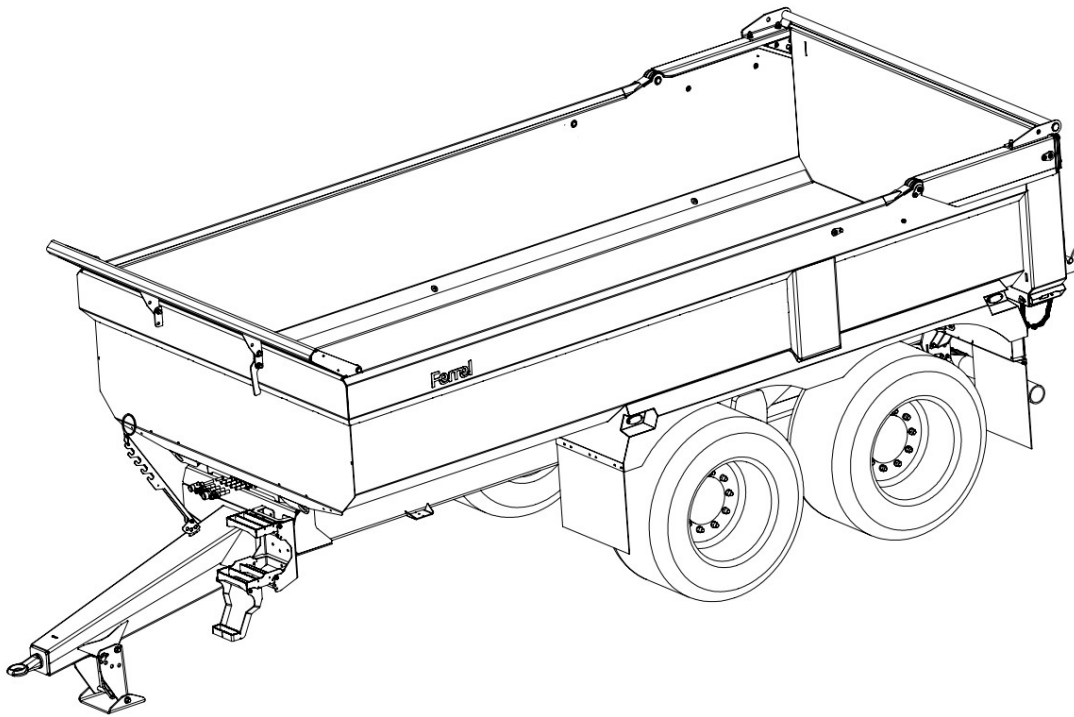


# Ferrel

## Dumper Trailer with hydraulic tailgate (DH) User manual



# 1. Content

1. Content.....	1
2. INTRODUCTION .....	4
3. TECHNICAL SPECIFICATIONS.....	5
4. SAFETY .....	6
5. OPERATION GUIDE .....	8
6. MAINTENANCE .....	10
1. Lubrication.....	10
2. Tilting flange .....	11
3. Tires .....	13
1. Choosing the right tire pressure:.....	13
4. Hydraulics .....	14
5. Wheels.....	14
7. AXLE MAINTENANCE .....	15
8. SECTIONS AND DETAILS.....	16
1. Components for 135DH.....	16
2. Components for 165DH.....	17
3. Components for 195DH.....	18
4. Components of frame 135R .....	19
5. Components of frame 165R/195R.....	28
2. Components of parking stand .....	39
3. Components of rear light frame .....	39
4. Components of rear guard .....	40
5. Components of bogie .....	41
6. Components of steps.....	45
6. Spring suspension drawbar .....	46
1. Frame assembly 165R.03.00.00/195R.03.00.00.....	46
2. Spring suspension components.....	47
7. Components of DH box .....	48
8. Mudguards and mudflaps.....	53
1. Basic mudguard and mudflaps .....	53
2. 135DH mudguards with lights and mudflaps .....	54
3. 165DH/195DH advanced mudguards with lights and mudflaps .....	56
9. Components of rear hatch.....	59
10. Components of arms .....	60
11. Setup of rear hatch.....	61
12. Hydraulic system .....	63
1. 135DH.....	63

2.	165DH/195DH.....	68
3.	Hydraulic cylinder repairs.....	73
13.	Electrics.....	73
1.	Electrical scheme for 135DH and 165DH:.....	73
2.	7 pin connector scheme .....	74
3.	Connection of lights.....	74
4.	Repairs .....	75
14.	Handbrake .....	75
1.	Scheme of handbrake 135R.....	76
2.	Scheme of handbrake 165R/195R.....	76
3.	Components of handbrake.....	77
9.	EXTENSION.....	78
1.	INTRODUCTION .....	78
2.	TECHNICAL SPECIFICATIONS.....	78
3.	SAFETY .....	78
4.	MAINTENANCE .....	78
5.	SECTIONS AND DETAILS.....	79
1.	Main components of extension.....	79
6.	Extension assembling instruction 135DH/165DH .....	91
2.	Step 1.....	91
3.	Step 2.....	92
4.	Step 3.....	93
5.	Step 4.....	94
7.	Accessories .....	97
1.	Ladder with support legs FE00.15.00.00 .....	97
8.	Sheeting.....	99
1.	Components of sheeting set.....	99
2.	Components of main cover .....	100
3.	Cover installation guide.....	101
4.	Operation instructions.....	103
10.	WARRANTY CONDITIONS .....	105

CONFORMITY CERTIFICATE

Manufacturer: Ferrel AS

Location: Põllu 3, Sõmeru, Lääne-Virumaa, 44201, Estonia,

Confirms that the trailer FERREL

Production date: \_\_\_\_\_

Into use taking date : \_\_\_\_\_

VIN code: V6R34A2\_\_\_\_\_

Complies with the requirements and conditions of the "Machinery and equipment safety regime" (RT 1 1993, 75,1103) and Directive 2006/42 / EU. And it has the EU-167/2013 Certificate of Conformity.

Lääne-Virumaa, Estonia

(place)

\_\_\_\_\_

( date )



Taavi Lust  
Manager

## 2. INTRODUCTION

This manual provides a comprehensive overview of the FERREL DH trailers. Read this manual carefully before using the trailer. Compliance with these requirements guarantees the safe and durable use of the product.

The FERREL DH trailer is intended only for transport operations of an agricultural nature. The most optimal field of application for DH trailers is carrying heavy materials (i.e. gravel, sand, soil). Only a tractor with a suitable coupling device and equipped with suitable hydraulic couplings is allowed as a means of transport. The main function of the trailer is to carry out transport operations and roll down the load in the back direction.

Particular attention must be paid to the maintenance of the trailer. If problems occur, contact the manufacturer or authorized retailer. The trailer user is required to comply with all the rules and requirements contained in this manual.

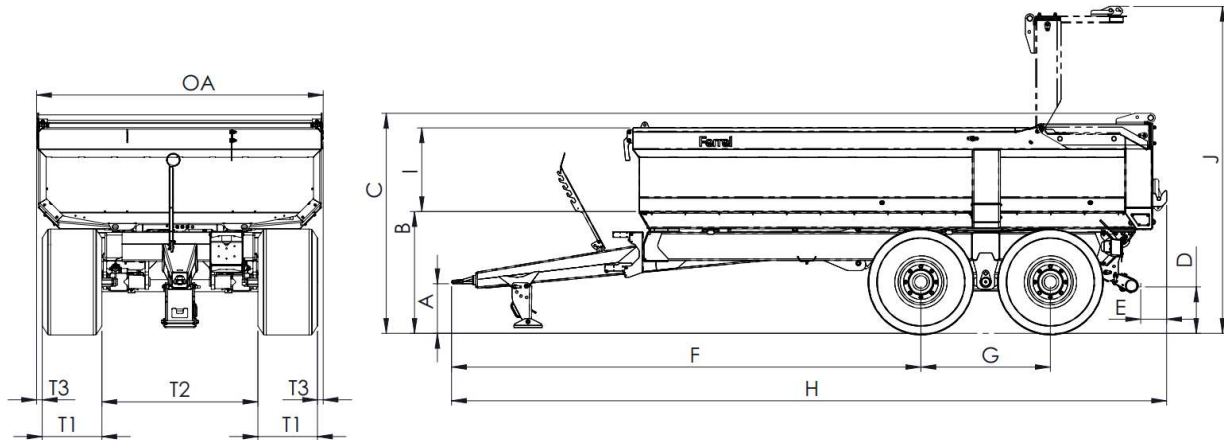
Ferrel DH trailers are divided into variants according to the carrying capacity:

- 135DH – 13,5 tons
- 165DH – 16,5 tons
- 195DH – 19,5 tons

### 3. TECHNICAL SPECIFICATIONS

Mass properties			
	135DH	165DH	195DH
Empty weight, t	4,1	4,7	5,3
Load capacity, t	13,5	16,5	19,5
Total weight, t	17,6	21,2	24,8
Capacity, m <sup>3</sup>	8,0	10,0	12,5
Required hydraulic pressure, bar	180...200	180...200	180...200
Speed limit, km/h	40	40	40

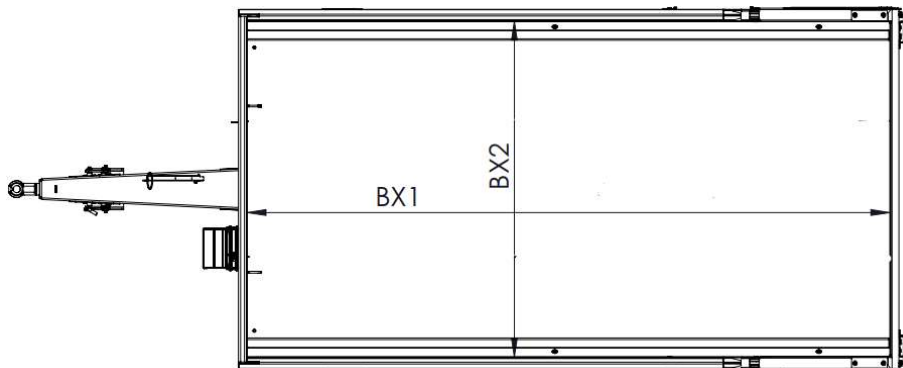
**Table 3.1.** – Trailer mass properties



**Figure 3.2.** – Trailer external dimensions

External measures														
Dumpers	T1	T2	T3	OA	A	B	C	D	E	F	G	H	I	J
<b>135DH</b>	500	1400	70	2550	390	1100	1952	380	230	4115	1150	6360	740	2900
<b>165DH</b>	560	1330	50	2550	360	1250	2240	530	240	4190	1300	6760	860	3180
<b>195DH</b>	600	1290	10	2550	380	1300	2410	590	320	4260	1300	7275	980	3360

**Table 3.2.** Trailer external dimensions

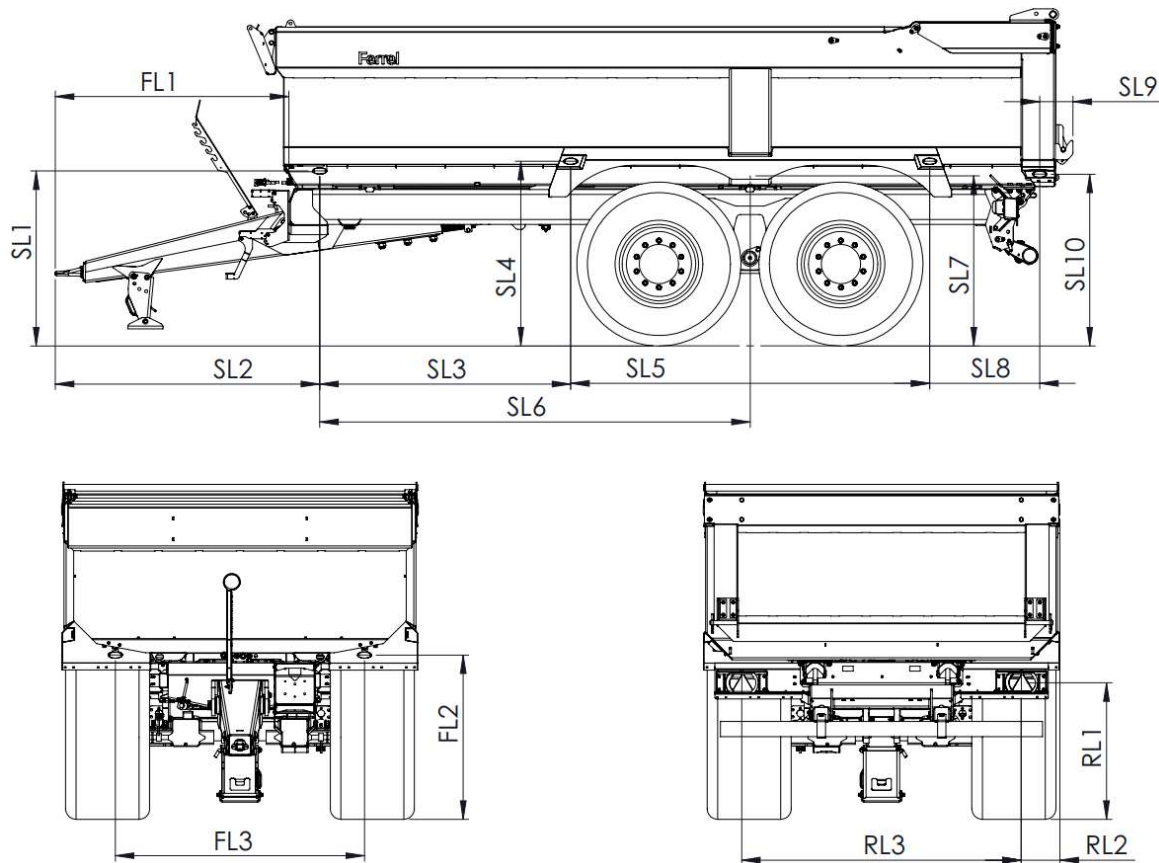


**Figure 3.3.** – Trailer internal dimensions

Box internal measures		
Dumpers	BX1	BX2

<b>135DH</b>	4500	2350
<b>165DH</b>	4950	2350
<b>195DH</b>	5450	2350

**Table 3.3.** Trailer internal dimensions



**Figure 3.4.** Position of lights

	*Front lights			*Side lights										Rear lights		
Trailer	FL1	FL2	FL3	SL1	SL2	SL3	SL4	SL5	SL6	SL7	SL8	SL9	SL10	RL1	RL2	RL3
<b>135DH</b>	1670	960	1780	1050	1890	N/A	N/A	N/A	2830	1050	N/A	240	1030	770	275	2000
<b>165DH</b>	1670	1130	1780	1200	1890	1720	1270	2560	3000	1200	N/A	240	1180	930	275	2000
<b>195DH</b>	1670	1170	1780	1250	1890	1790	1320	2560	N/A	N/A	780	240	1230	980	275	2000

\* - accessories

**Table 3.4.** Position of lights

## 4. SAFETY

- Before using the trailer, read this guide thoroughly. The user must have a valid driver's license for the tractor and trailer.
- Use the FERREL trailer only as intended.
- Before starting work, make sure that the brakes and lights are working.
- Do not use accessories not recommended by the manufacturer.
- Do not rebuild the trailer if that is not approved by the manufacturer.
- Do not overload the trailer (check the permissible load weight from documents or ask the trailer dealer or manufacturer).
- To keep the box in upper position, use only the original support. NB! Make sure the box is empty before performing it.

- Make sure unindenting movement has been prevented (i.e. parking brakes; chocks) before servicing and repairs.
- In traffic according to traffic rules.
- Regularly monitor the hydraulics system. Remove malfunctions instantly.
- Before carrying out any maintenance and repair work on the hydraulic system, make sure there is no pressure on the system.
- Avoid releasing hydraulic oil to the environment.
- Avoid contact with oil. Use goggles and gloves.
- If working near the power lines, follow the appropriate safety radius.
- When replacing or repairing wheels or hubs, install the jack on the bottom of the boggie. Make sure that the lifting gear (jack) is firmly grounded and there is a material (rubber or wood) that prevents slipping between the lifting device and the tip of the boggie.
- In the case of change a full boggie, the whole trailer must be fixed to the position-
- It is prohibited to carry goods and equipment with a center of gravity above the trailer's height from the trailer side.
- The trailer is permitted to run on a maximum side curve on a surface with a slope of not more than 10%, with a speed not exceeding 20 km/h. When moving on a coarse soil, the maximum speed of 10 km/h is allowed to prevent overturning.
- Do not tilt the box on a side slope deeper than 5 degrees.
- Do not climb into the trailer from underneath the back hatch. If it is unavoidable, block the rear hatch with a solid object.
- When working with hydraulics or reversing make sure bystanders are safe.
- Do not attempt to rock the trailer when it is fully extracted – it will damage the tilting cylinder
- Do not overload the trailer
- Open the rear hatch before tilting the trailer – fast moving heavy objects could damage the rear hatch.

**NB! STRONGLY IS PROHIBITED**

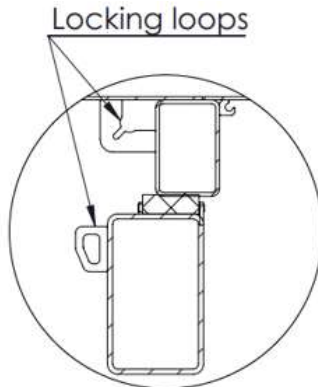
- Work with a trailer under the influence of alcohol, narcotic drugs or psychotropic substances.
- Use the trailer to transport people.
- Check hydraulic leaks by hand.
- Improve tires independently. Contact a qualified service representative or replace the entire damaged tire.
- Never put any part of the body between moving parts unless unintended movement has been limited to safe distance.



## 5. OPERATION GUIDE

1. All Ferrel DH trailers can be connected with a chain for the time of lifting the trailer on and off the transport trailer. Normally rear hatch limiting chain is used.

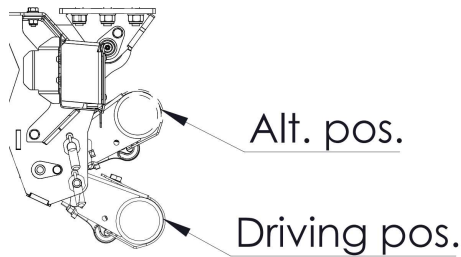
**NB! Remove the chain right after lifting (or driving) the trailer off the transport device. Leaving it intact may cause severe damage during normal use of the trailer.**



**Figure 5.1.** Box and frame locking points.

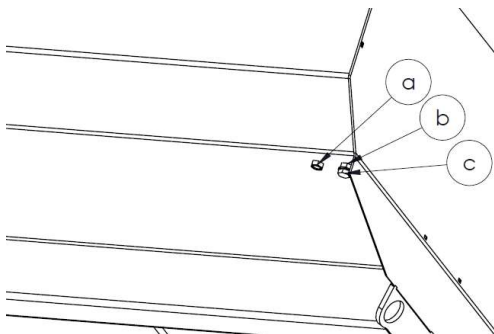
2. When connecting the trailer to a tractor, use only the coupling device for this purpose.  
Make sure:
  - The trailer is stable on a flat surface;
  - Hydraulic hoses and electrical cables are intact;
  - The brakes and lights are in operation.
  - All trailer hydraulics fittings and electrical connector are securely connected to the tractor for the connection required for this purpose.
3. Before changing the position of the trailer, do not forget to lift the support leg!
4. Work with a trailer may be carried out only by a worker with the corresponding qualifications and / or driving license.
5. Make sure that nobody is in the working area when tilting the.  
Safety radius is 10 m.
6. For the time of loading, we recommend that you apply the parking brake.
7. Do not overload the trailer!

8. The trailer does not allow the towing of a second coupling.
9. When you are driving backwards, make sure that nobody is behind the trailer!
10. Before starting to move make sure that the rear hatch is closed and the load is positioned as evenly as possible.
11. While driving, make sure that the trailer moves exactly behind the tractor. Be aware that the trailer may be wider than many tractors used for transporting. Do not endanger your companions!
12. Do not exceed the speed limit what recommended by the manufacturer! Adjust the travel speed according to road and weather conditions. Be extra careful when crossing the curves!
13. Rear guard can be lifted for driving in rough conditions. For driving on public roads, the rear guard must be on driving position.



**Figure 5.13.** Rear guard positions

14. There is no need to use special tools to use the trailer.
15. Pay attention to possible risks of obstacles when maneuvering with the raised box - avoid contact with air lines and other obstacles.
16. When trailer is stationary for a longer period of time, it is recommended to open the drain holes to keep rain water from pooling in the box:
  - Remove plug "c" from drain hole "d" (bolt DIN 933 M16x25)
  - Keep the plug in its storage nut "a" for longer periods
  - Put the plug "c" back into the drain hole before loading the trailer



**Figure 5.16.** Draining solution

17. When parking a trailer independently (without a tractor), make sure that there is no transported goods or equipment in the trailer box.

18. All Ferrel trailers can be equipped with hydraulic service brakes, and all users must consider this. A tractor or tractor equipped with a hydraulic brake extract can be connected to the trailer. NB! One can also order a trailer equipped with pneumatic brakes or both (one of the axles is hydraulic or the other with pneumatic brakes).

19. When the brakes are weakened, tighten the brake lever adjustment bolt.

Take up the slack when the actuator stroke reaches about two thirds of the maximum stroke.

To take up the slack, turn the adjustment screw on the lever to adjust the relative position of the cam and lever. (Figure shown below).

***After adjustment ensure that brakes are not touching when released, to prevent overheating brakes!***

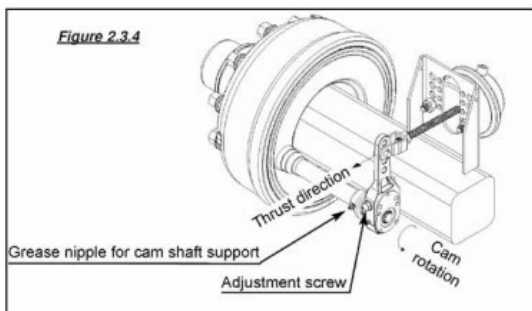
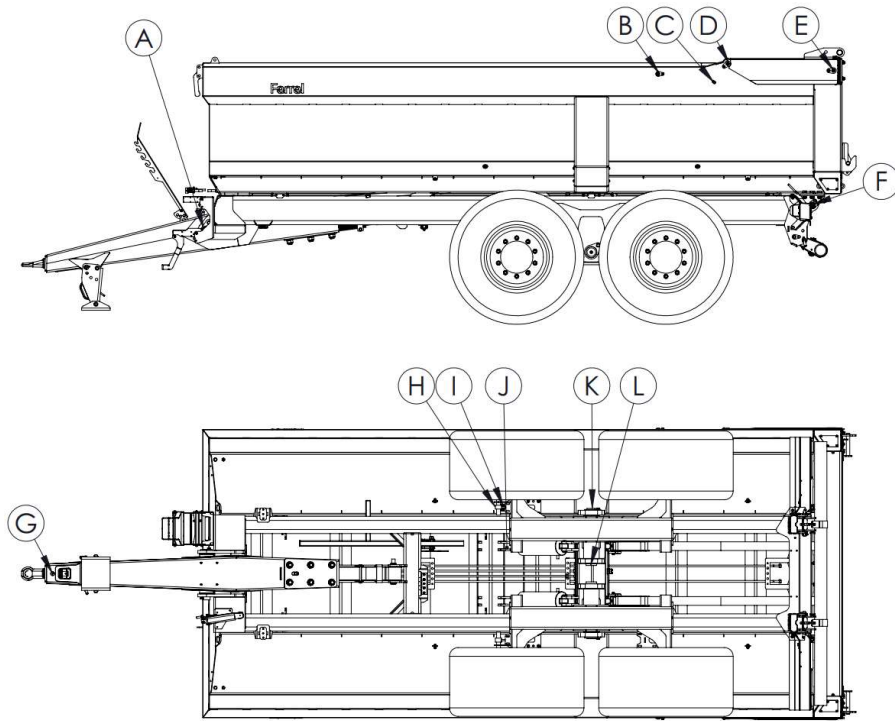


Figure 5.19. - brake lever adjustment

## 6. MAINTENANCE

### 1. Lubrication

- Lubricate the trailer through lubrication points every 16 hours. Depending on the variant or version the lubrication point position and quantity may vary:



**Figure 6.1.** – lubrication points

Number of lubrication points:

	A	B	C	D	E	F	G	H*	I*	J	K	L
<b>135DH</b>	N/A	2x	2x	2x	2x	2x	1x	2x (4x)	2x (4x)	1x	2x	2x
<b>165DH</b>	2x	2x	2x	2x	2x	2x	1x	2x (4x)	2x (4x)	2x	2x	2x
<b>195DH</b>	2x	2x	2x	2x	2x	2x	1x	2x (4x)	2x (4x)	2x	2x	2x

\* - No brake version has no lubrication points.

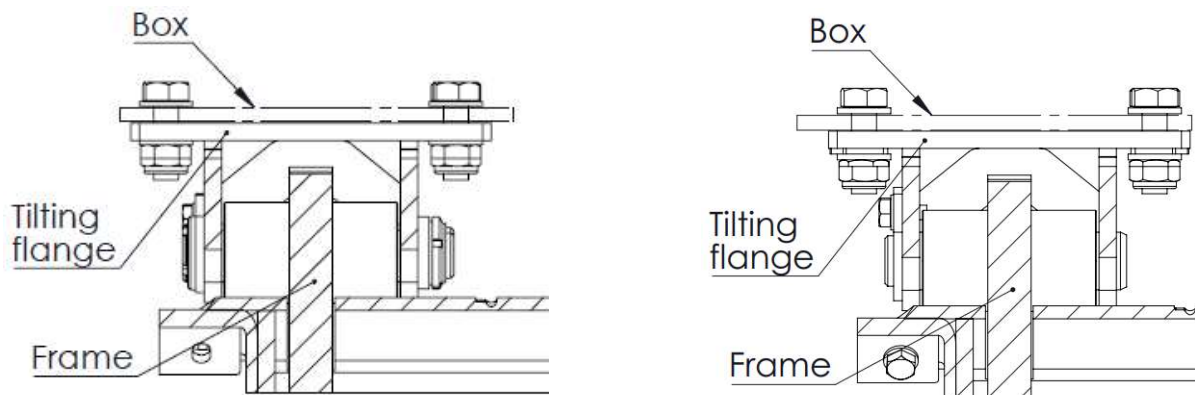
**Table 6.1.** – lubrication points

## 2. Tilting flange

- Connecting bolts between box and tilting flange should be regularly tightened (12psc. M20 bolt joints).

Tightening force – 400 Nm. Tightening frequency:

- After first 8hours of operation
- After every 3 months of operation



- Version "A" – Pin with a nut

Version "B"- Pin without a nut

- Figure 6.2 – Tilting flange connection.

### 3. Tires

- Regularly check the tire pressure, that is marked on tire. Maximum permitted pressures are:

		500/50 R17 Ridemax FL 693 M									
Km/h \ bar	bar	1.0	1.2	1.6	2.0	2.4	2.8	3.2	3.6	4.0	5.0
40		1465	1640	1990	2255	2610	2965	3275	3585	<b>3935*</b>	4420
25		1695	1900	2315	2620	3030	3445	<b>3800*</b>	4160	4575	5135
10		1935	2165	2635	2985	3455	<b>3920*</b>	4330	4740	5210	5850

		560/45 R22.5 Ridemax FL 693 M									
Km/h \ bar	bar	1.0	1.2	1.6	2.0	2.4	2.8	3.2	3.6	4.0	
40		1790	2030	2415	2850	3265	3625	<b>4060*</b>	4445	<b>4830**</b>	
25		2080	2360	2805	3310	<b>3790*</b>	4210	<b>4715**</b>	5165	5610	
10		2365	2685	3195	<b>3775*</b>	4315	<b>4795**</b>	5370	5880	6390	

		600/50 R22.5'' BKT FL-630 Ultra TL									
Km/h \ bar	bar	0.8	1.0	1.2	1.6	2.0	2.4	2.8	3.2	3.6	4.0
40		1920	2220	2520	3040	3540	4050	<b>4555**</b>	5020	<b>5520***</b>	6000
25		2215	2560	2905	3510	4080	<b>4675**</b>	5210	<b>5800***</b>	6365	6915
10		2520	2915	3310	4000	<b>4650**</b>	5325	<b>5940***</b>	6600	7245	7875

		710/45 R22.5'' BKT FL-639 Ridamax TL									
Km/h \ bar	bar	1.0	1.2	1.6	2.0	2.4	2.8	3.2	3.6	4.0	
40		2560	2875	3575	4065	<b>4695**</b>	5325	<b>5815***</b>	6375	7005	
30		2840	3190	3970	4515	<b>5215**</b>	<b>5915***</b>	6460	7080	7780	
25		2975	3340	4155	<b>4725**</b>	<b>5455***</b>	6190	6760	7410	8140	
10		3385	3805	<b>4730**</b>	5380	<b>6215***</b>	7050	7695	8440	9270	

**Table 6.3.** – Permitted tire pressures

Minimum tire pressures for given speeds for DH trailers are marked as: \* 135DH; \*\*165DH; \*\*\*195DH

#### 1. Choosing the right tire pressure:

Correct tire pressure will prolong the lifespan of tires, lessen the fuel consumption, damages less soil and improve the traffic safety.

Choose the corresponding tire pressure according to the formula [Minimum tire pressure = total weight/4].

Optimal tire pressure depends on the job conditions:

	Mainly off-road	Mainly on-road
--	-----------------	----------------

Low tire pressure	<ul style="list-style-type: none"> <li>+ Compress soil less.</li> <li>+ Tire sinks less.</li> <li>+ Lower fuel consumption.</li> <li>- Load to be carried is limited by tire pressure.</li> <li>- Pointy objects are more likely to damage tire.</li> <li>- Risk to have tire pushed off the rim on sharp turns.</li> </ul>	<ul style="list-style-type: none"> <li>- Increased wear.</li> <li>- Increased fuel consumption.</li> <li>- Unstable in high speeds.</li> <li>- Load to be carried is limited by tire pressure.</li> <li>- Max speed is limited by tire pressure.</li> </ul>
High tire pressure	<ul style="list-style-type: none"> <li>+ Load to be carried is limited by trailer construction.</li> <li>- Higher soil compression.</li> <li>- Increased fuel consumption.</li> </ul>	<ul style="list-style-type: none"> <li>+ Lower fuel consumption.</li> <li>+ More stable in high speeds.</li> <li>+ Load to be carried is limited by trailer construction.</li> </ul>

**Table 6.3.1-** Pros and cons of tire pressure levels

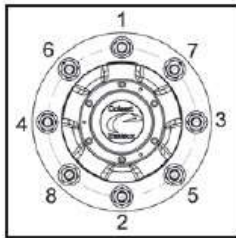
#### 4. Hydraulics

- Regularly check for hydraulic hoses and electrical conductors, but not less than 40 operating hours.

#### 5. Wheels

After the first 8 hours of operation, tighten the wheel nuts. Later check and tighten nuts as needed every 40 operating hours.

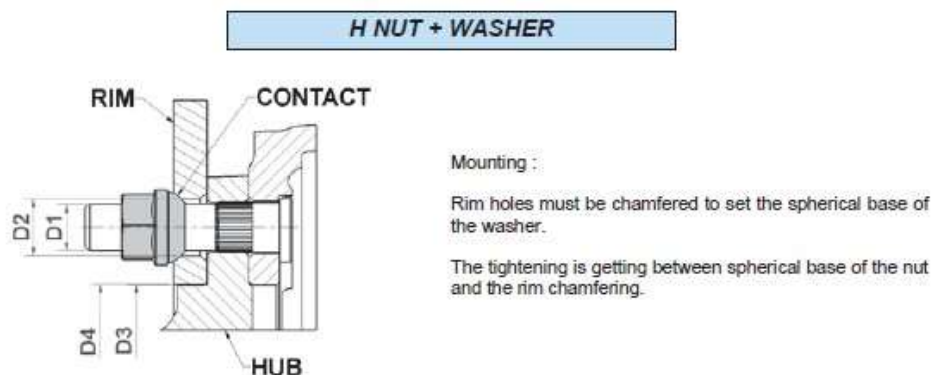
Retighten nuts after every 6 months or 25000km.



- Wheel nuts should be tightened diagonally using torque wrench as followed:

**Figure 6.5.** – wheel nut tightening sequence

1. Tire 15,5" – 270 Nm
2. Tire 17" – 350 Nm
3. Tire 22,5" – 450 Nm



Spanner	Nb stud x $\emptyset$ interaxial	Wheel stud D1	Tightening	$\emptyset$ Hole rim D2	$\emptyset$ Hub D3	$\emptyset$ Inner rim D4
mm	mm	mm	Nm	mm	mm	mm
24	6 x $\emptyset$ 205	M18x1.5	270 (+20/0)	21.5	160	161
30	8 x $\emptyset$ 275	M20x1.5	350 (+30/0)	27	220	221
30	10 x $\emptyset$ 335	M22x1.5	450 (+60/0)	27	280	280

Figure 6.5 – Axle components

## 7. AXLE MAINTENANCE

- Check the wheel bearing clearance:  
After the first 1000 km  
Before intensive use, every 6 months or 25,000km
- To check the wheel bearings:  
Lift the wheel off the ground  
Turn in both directions slowly to check for any rough points or friction  
Turn it at high speed to check for unusual noises, such as grating or knocking
- ***If the bearing is damaged or worn, the bearing seals should all be replaced***

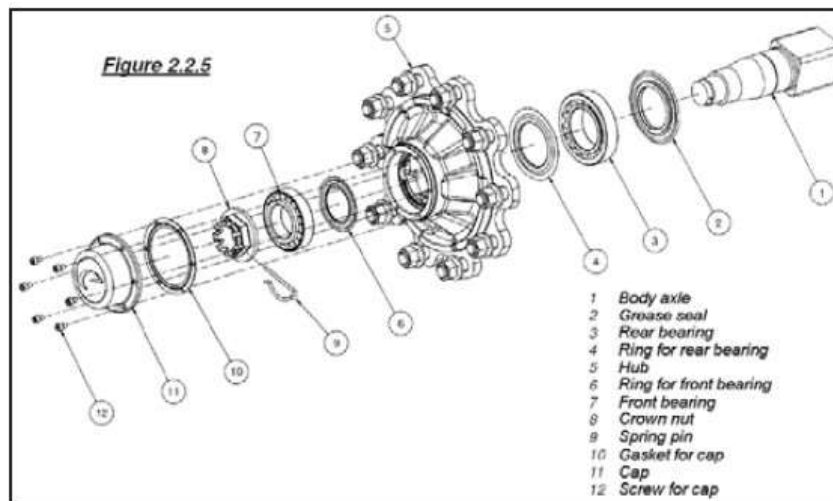


Figure 6.7. – Axle componenets

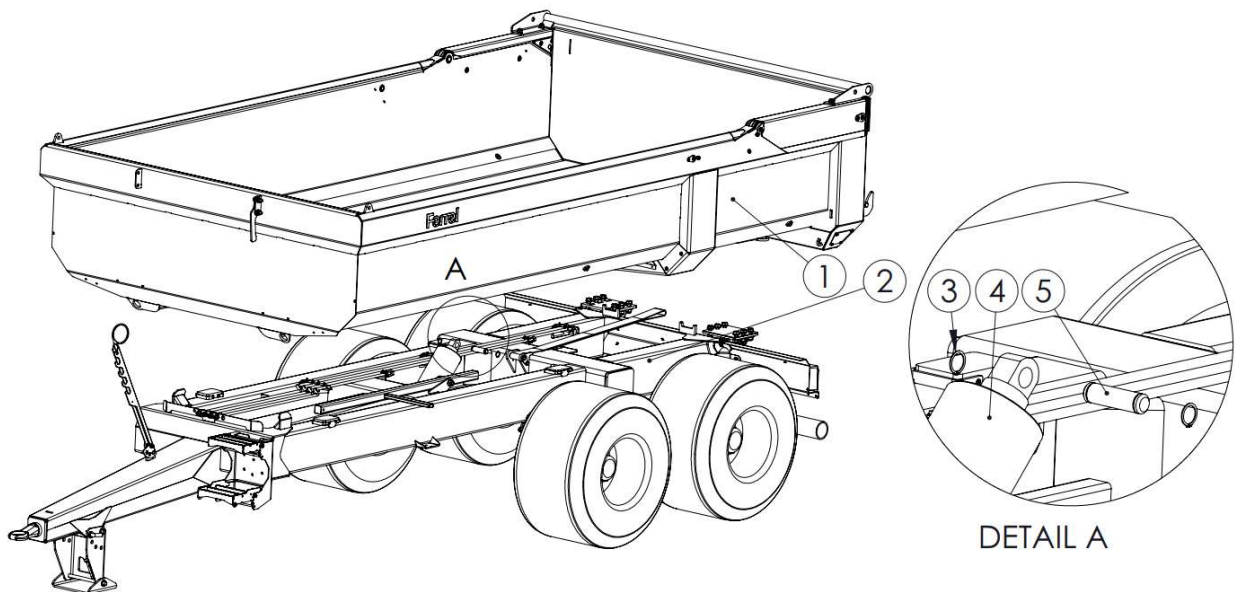
- Adjusting the wheel bearings:  
Lift the axle until the wheel is no longer resting on the ground.  
Large wheels should be removed so that the clearance is easier to feel and to make it easier to adjust the bearings  
Remove hubcap  
Remove the cotter pin or hair-pin clip from the spindle  
Tighten the castle nut to take up the internal clearance. The conical roller bearings should then be firmly held between the hub seating, the pressure ring, spindle and castle nut.  
***The rotation of the hub or wheel feels to be slightly stiff:***  
-Slacken the castle nut until there is no longer any friction between the castle nut and the outer bearing and the hole for the pin is aligned with a notch in the castle nut.  
-Tap the hub gently using a mallet to shake down the assembly.  
-Check that the hub rotates more freely.  
-Always err on the side of too free than too tight.



- When the hub has been adjusted, fit new split cotter pin or re-fit the hair-pin clip.
  - Refit the hubcap.
  - Refit the wheel.
  - Lubricating the wheel bearings:
    - In normal conditions, lubricate the bearings every 2 years or every 50,000 km.
    - Or when the brake shoes are replaced, in harsh conditions the bearings should be lubricated more frequently.
    - Use general purpose EP grease formulated for plain, ball and roller bearings.
- Before reassembly, ALL parts should be degreased and perfectly clean from debris and old and dirty grease!**
- Precise instructions and information for ADR axle maintenance:  
<http://www.adraxles.com/EN/res/726/Colaert-Essieux---Maintenance-Manual.pdf>

## 8. SECTIONS AND DETAILS

### 1. Components for 135DH

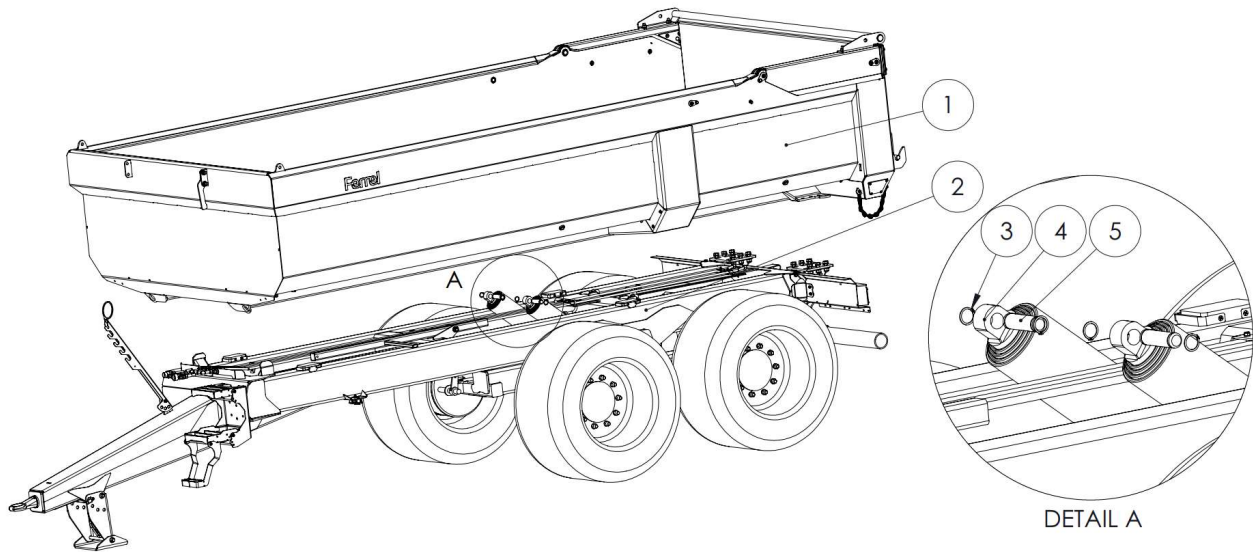


**Figure 8.1.** - Main assembly 135DH

Component	NO.	QTY	Fastening to frame/ box	Versions
135DH box	1	1	Same as 135R	
135R frame	2	1	M20x55 DIN933; 12psc DIN 6916 VH300 M20; 24psc M20 DIN985; 12psc	No brakes 1+1 brake (hydraulic or pneumatic) 2+2 brakes (hydraulic or pneumatic) 2+2 brakes (hydraulic and pneumatic combo)
Retaining ring	3	2		DIN471 D30
Tilting Cylinder	4	1		NAT 6
Pin ST0013	5	1		D30 L80

**Table 8.1.** - Components of main assembly 135DH

## 2. Components for 165DH

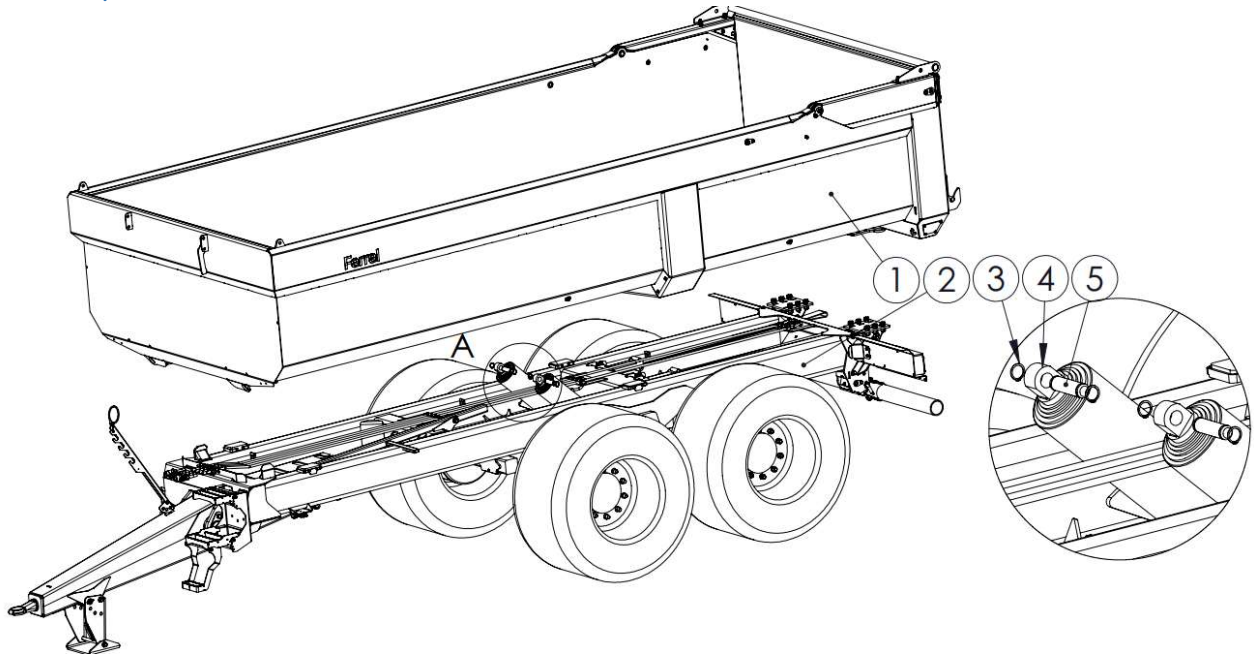


**Figure 8.2.** - Main assembly 165DH

Component	NO.	QTY	Fastening to frame/ box	Versions
165DH box	1	1	Same as 165R	
165R frame	2	1	M20x55 DIN933; 12psc DIN 6916 VH300 M20; 24psc M20 DIN985; 12psc	No brakes 1+1 brake (hydraulic or pneumatic) 2+2 brakes (hydraulic or pneumatic) 2+2 brakes (hydraulic and pneumatic combo)
Retaining ring	3	4		DIN471 D30
Tilting Cylinder	4	2		NAS 5
Pin ST0013	5	2		D30 L80

**Table 8.2.** - Components of main assembly 165DH

### 3. Components for 195DH



**Figure 8.3.** - Main assembly 195DH

Component	NO.	QTY	Fastening to frame/ box	Versions
195DH box	1	1	Same as 165R	
195R frame	2	1	M20x55 DIN933; 12psc DIN 6916 VH300 M20; 24psc M20 DIN985; 12psc	No brakes 1+1 brake (hydraulic or pneumatic) 2+2 brakes (hydraulic or pneumatic) 2+2 brakes (hydraulic and pneumatic combo)
Retaining ring	3	4		DIN471 D30
Tilting Cylinder	4	2		NAT 6
Pin ST0013	5	2		D30 L80

**Table 8.3.** - Components of main assembly 165DH

#### 4. Components of frame 135R

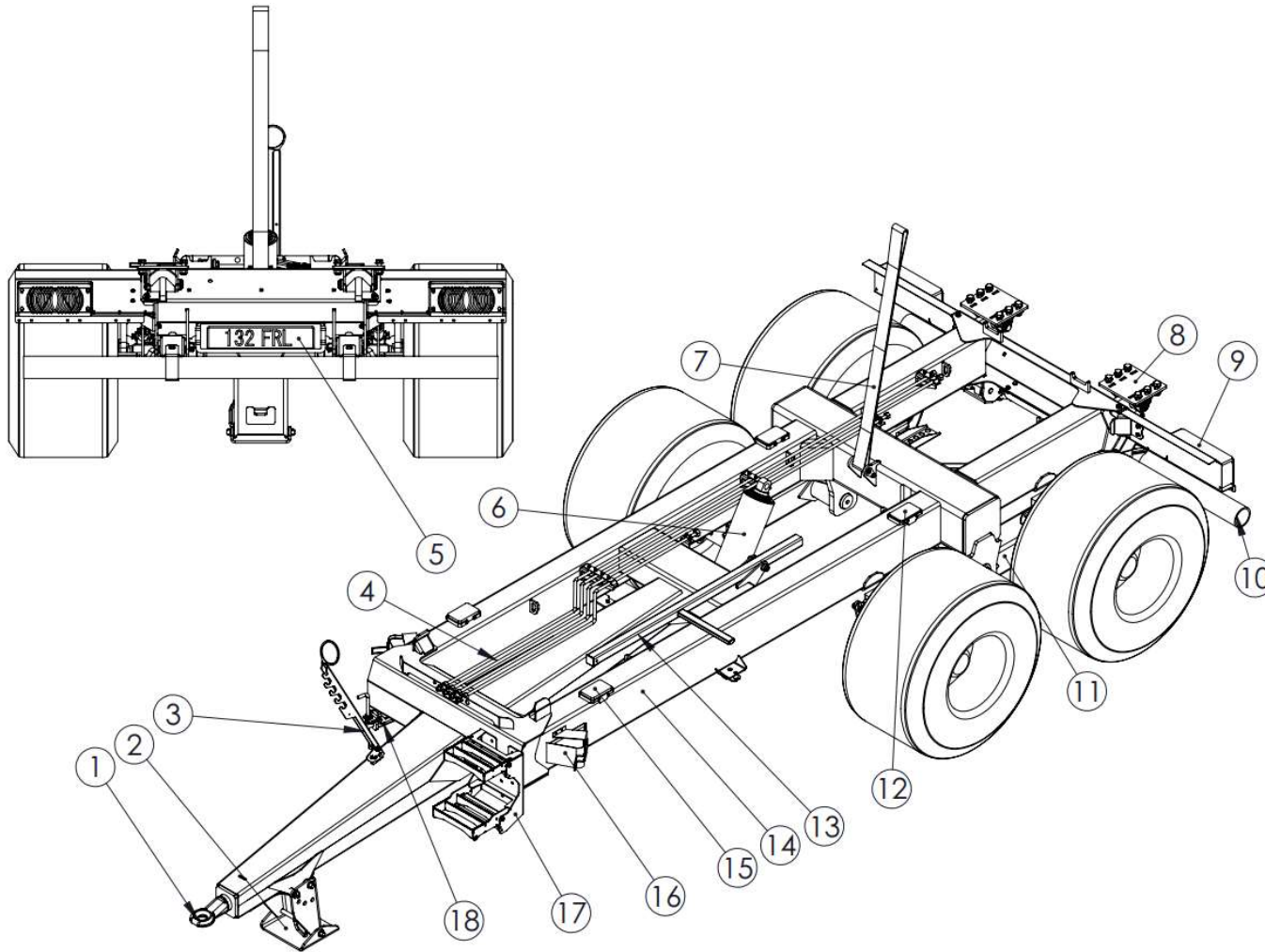
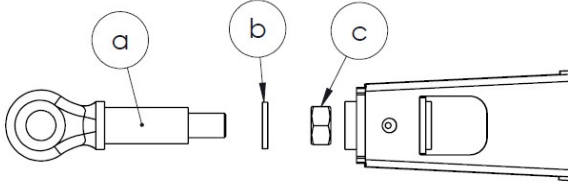
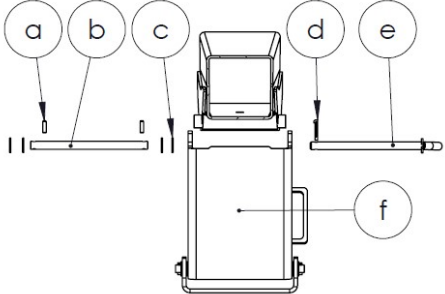
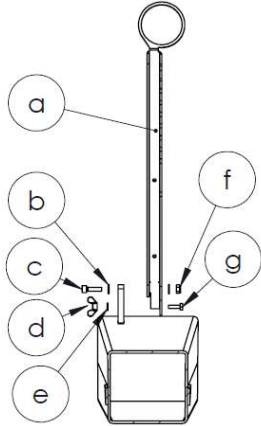
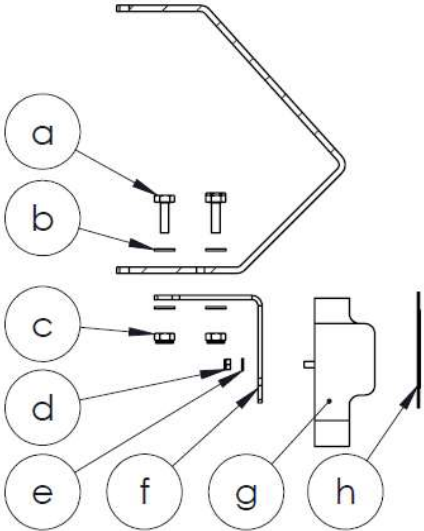
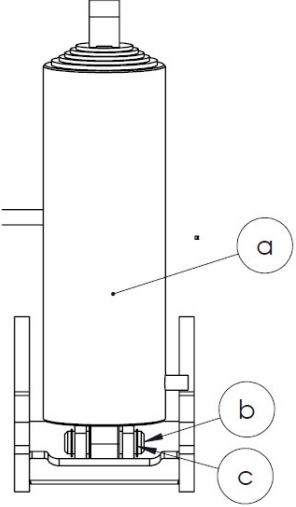


Figure 8.4. – Components of frame 135R

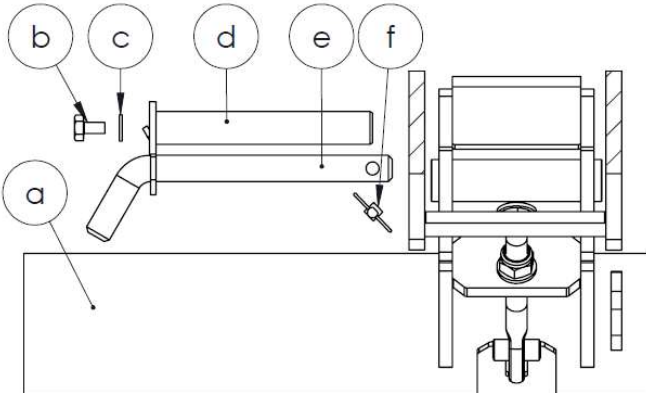
Pos.	QTY	Part name	Part No	Assembly drawing	Components
1	1	Towing eye	HS17T-02		<ul style="list-style-type: none"> <li>a. Towing eye – HS17T-02 (1psc)</li> <li>b. Washer – HS17T-04 (1psc)</li> <li>c. Nut – DIN 24032 M42 (1psc)</li> </ul>
2	1	Parking stand	135R.07.01.00		<ul style="list-style-type: none"> <li>a. Spring pin d8 L30 (2psc)</li> <li>b. ST0012; D20_L330_2xd8_EL (1psc)</li> <li>c. Washer M20 (4psc)</li> <li>d. Splint pin DIN 11023 D4,5 (1psc)</li> <li>e. ST0001.00; D20 L265 (1psc)</li> <li>f. 135R.07.01.00 (1psc)</li> </ul>
3	1	Pipe holder	ST0018		<ul style="list-style-type: none"> <li>a. ST0018 (1psc)</li> <li>b. Washer DIN 125 M12 (2psc)</li> <li>c. Bolt DIN 912 M12x40 (1psc)</li> <li>d. Wing nut DIN 315 M10 (1psc)</li> <li>e. Washer DIN 125 M10 (1psc)</li> <li>f. Nut DIN 985 M12 (1psc)</li> <li>g. Bolt DIN 933 M10x30 (1psc)</li> </ul>
4	1	Hydraulics		See section "Hydraulics"	

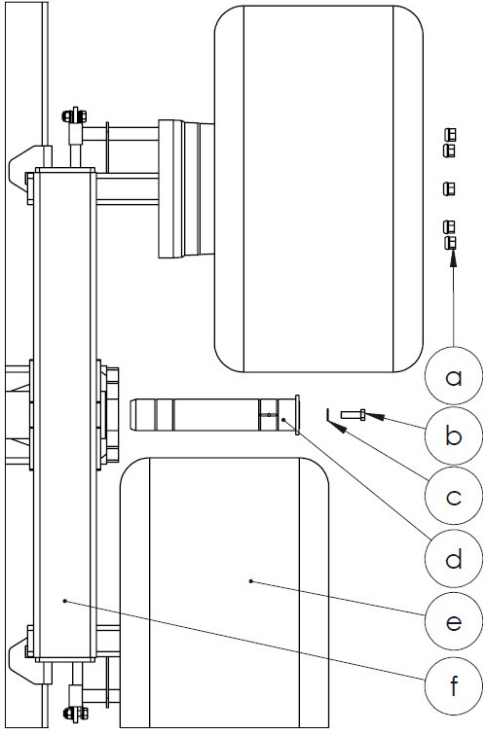
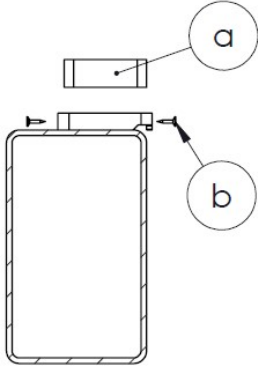
5	1	Number plate	ST0016		<ul style="list-style-type: none"> <li>a. Bolt DIN 933 M10x30 (4psc)</li> <li>b. Washer DIN 125 M10 (8psc)</li> <li>c. Nut DIN 985 M10 (4psc)</li> <li>d. Nut DIN 985 M6 (2psc)</li> <li>e. Washer DIN 125 M6 (2psc)</li> <li>f. ST0016 (1psc)</li> <li>g. Registration plate holder (1psc) <ul style="list-style-type: none"> <li>g1. RP1 (without light)</li> <li>g2. RP2 (with light)</li> </ul> </li> <li>a. Registration plate (not supplied by Ferrel AS)</li> </ul>
6	1	Tilting cylinder	NAT6		<ul style="list-style-type: none"> <li>b. NAT6 (1psc)</li> <li>c. ST0013 D30 L85 (1psc)</li> <li>d. Retaining ring DIN 471 D30 (2psc)</li> </ul>

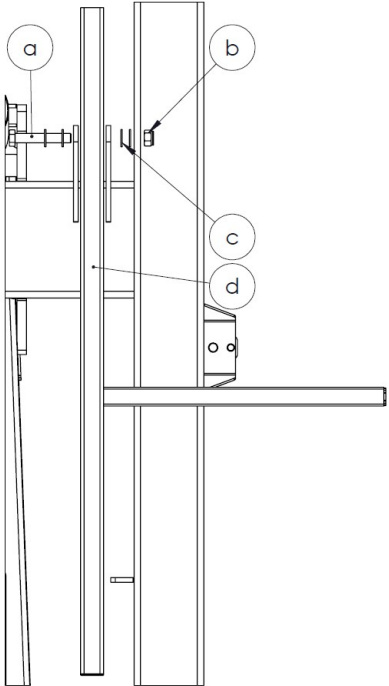
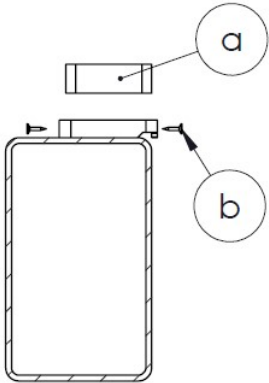
7	1	Tilting limiter	OT0024_13D		<ul style="list-style-type: none"> <li>a. OT0024_13D (1psc)</li> <li>b. ST.0003.00 25x125 (1psc)</li> <li>c. Washer DIN 125 M10 (1psc)</li> <li>d. Bolt DIN 933 M10x20 (1psc)</li> </ul>
8a	2	Tilt flange Version "A"	FE00.02.00		<ul style="list-style-type: none"> <li>a. Nut CRN 35x1,5 (1psc)</li> <li>b. Collar ST0024.4 TS-35,5-40,5-50 (1psc)</li> <li>c. Frame 165R</li> <li>d. Box 165DH</li> <li>e. Bolt DIN 933 M20x55 (6psc)</li> <li>f. Washer DIN 6916 VH300 M20 (12psc)</li> <li>g. FE00.02.00 (1psc)</li> <li>h. Nut DIN 985 M20 (6psc)</li> <li>i. Pin ST0024.01 TLK 40-150 (1psc)</li> <li>j. Heel ST0024.01 TLK40 (1psc)</li> <li>k. Washer DIN 125 M10 (1psc)</li> <li>l. Bolt Din 933 M10x16 (1psc)</li> <li>m. Grease nipple DIN 71412 M10x1 (1psc)</li> <li>n. Stopper collar DIN7993 A D40 (1psc)</li> <li>a. Collar ST0024.03 TLKV-40 (1psc)</li> </ul>

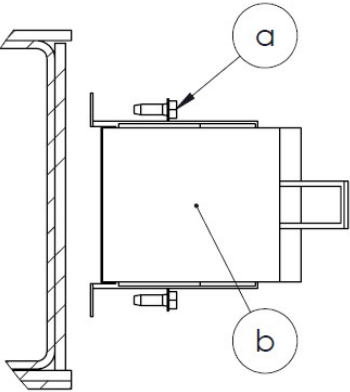
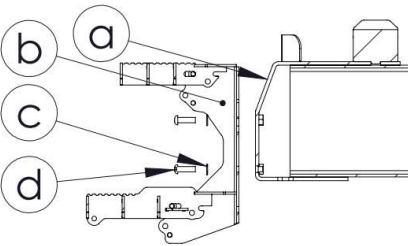
8b	2	Tilt flange Version "B"	FE00.02.00		<ul style="list-style-type: none"> <li>a. Frame 165R/195R</li> <li>b. Box 165DH</li> <li>c. Bolt DIN 933 M20x55 (6psc)</li> <li>d. Washer DIN 6916 VH300 M20 (12psc)</li> <li>e. FE00.02.00 (1psc)</li> <li>f. Plate FE00.02.00.02 (2psc)</li> <li>g. Nut DIN 985 M20 (6psc)</li> <li>h. Pin ST0004.00 40-150 (1psc)</li> <li>i. Grease nipple DIN 71412 M10x1 (1psc)</li> <li>j. Washer DIN 125 M10 (1psc)</li> <li>k. Bolt Din 933 M10x16 (1psc)</li> </ul>
9	1+1 R+L	Rear light flange	FE00.04.01.00		<ul style="list-style-type: none"> <li>a. Bolt DIN 933 M12x40 (3psc)</li> <li>b. Nut DIN 985 M12 (2psc)</li> <li>c. FE00.04.01.00 (1 right hand + 1 left hand)</li> <li>d. Washer DIN 125 M12 (5psc)</li> </ul>



10	1	Rear guard	FE00.07.00		<ul style="list-style-type: none"> <li>a. FE00.07.00 (1psc)</li> <li>b. Bolt DIN 933 M10x16 (2psc)</li> <li>c. Washer DIN 125 M10 (2psc)</li> <li>d. ST.0003.00 25x165 (2psc)</li> <li>e. ST0001.00 D20x160 (2psc)</li> <li>f. Splint pin DIN 11023 D4,5 (1psc)</li> </ul>
----	---	------------	------------	--	--

11	1+1 R+L	Bogie axle	135R.09.01.00		<ul style="list-style-type: none"> <li>a. Wheel nut DIN 74361 M20 (2x8 psc)</li> <li>b. Bolt DIN 933 M16x50 (1psc)</li> <li>c. Washer DIN 125 M16 (1psc)</li> <li>d. ST0022.00 D80x415 (1psc)</li> <li>e. Wheel with rim (2psc) <ul style="list-style-type: none"> <li>e1. W2 – 500/50 R17''</li> <li>e2. W3 – 560/45 R22,5''</li> </ul> </li> <li>f. 135R.09.00.00 (1psc) <ul style="list-style-type: none"> <li>f1. H0 – no brakes</li> <li>f2. H1 – 1 hydraulic brake (L/R)</li> <li>f3. H2 – 2 hydraulic brakes</li> <li>f4. P1 – 1 Pneumatic brake</li> <li>f5. P2 - 2 Pneumatic brake</li> <li>f6. HP - 1 hydraulic + 1 Pneumatic brake</li> </ul> </li> </ul>
12	2	Plastic cushion 2	OT00011		<ul style="list-style-type: none"> <li>a. OT00011 140x90x25 (1psc)</li> <li>b. Screw D3 L20 (4psc)</li> </ul>

13	1	Box support	FE00.07.00		<ul style="list-style-type: none"> <li>a. Bolt DIN 933 M20 x120 (1psc)</li> <li>b. Nut DIN 985 M20 (1psc)</li> <li>c. Washer DIN 125 M20 (4psc)</li> <li>d. FE00.07.00 (1psc)</li> </ul>
14	1	Frame	135R.01.01.00		
15	2	Plastic cushion 1	OT00011		<ul style="list-style-type: none"> <li>a. OT00011 140x90x30 (1psc)</li> <li>b. Screw D3 L20 (4psc)</li> </ul>

16	2	Chocks	OT0008.02		<ul style="list-style-type: none"> <li>a. Bolt DIN 7500 D8x20 (4psc)</li> <li>b. OT0008.01</li> </ul>
17	1	Steps	FE00.09.05.00.00		<ul style="list-style-type: none"> <li>a. Frame 135R.01.00.00</li> <li>b. Step FE00.09.05.00.00 (base)</li> <li>c. Washer DIN 125 M12 (3pcs)</li> <li>d. Bolt DIN 7380 M12x30</li> </ul>
18	1	Handbrake	FE00.06.00.00	See section "Handbake"	

**Table 8.4.** - Components of frame 135R

5. Components of frame 165R/195R.

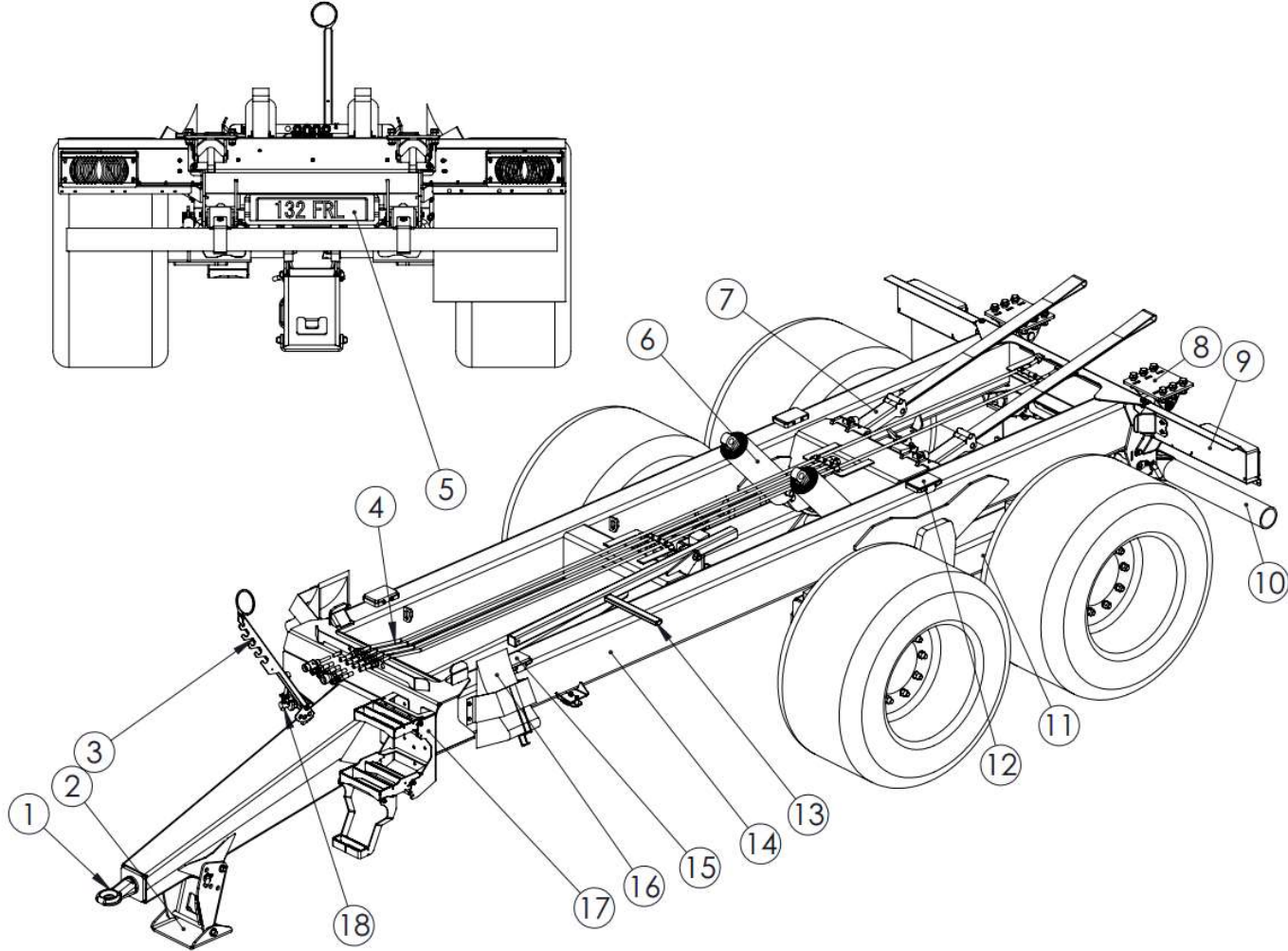
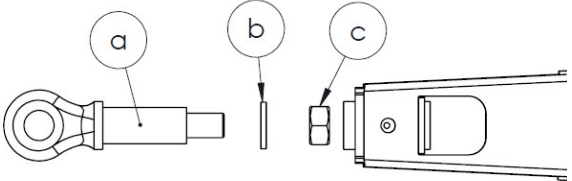
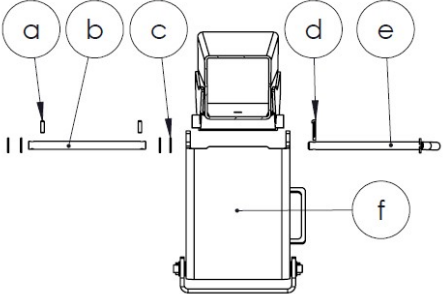
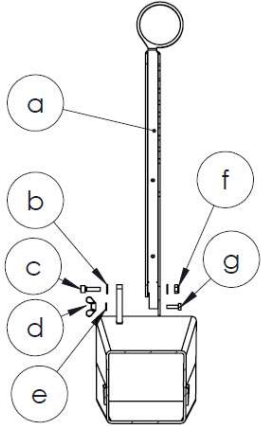
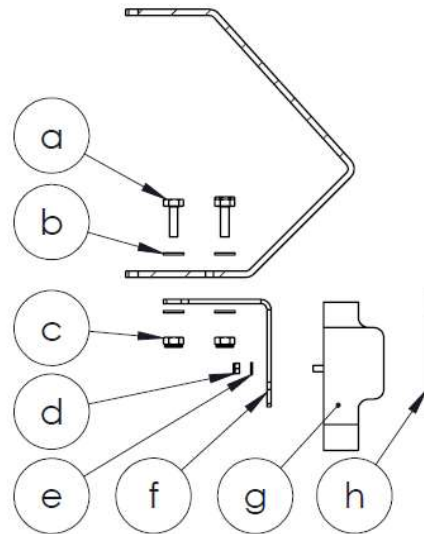


Figure 8.5. – Components of frame 165R/195R

Pos.	QTY	Part name	Part No	Assembly drawing	Components
1	1	Towing eye	HS17T-02		<ul style="list-style-type: none"> <li>a. Towing eye – HS17T-02 (1psc)</li> <li>b. Washer – HS17T-04 (1psc)</li> <li>c. Nut – DIN 24032 M42 (1psc)</li> </ul>
2	1	Parking stand	135R.07.01.00		<ul style="list-style-type: none"> <li>a. Spring pin d8 L30 (2psc)</li> <li>b. ST0012; D20_L330_2xd8_EL (1psc)</li> <li>c. Washer M20 (4psc)</li> <li>d. Linch pin DIN 11023 D4,5 (1psc)</li> <li>e. ST0001.00; D20 L265 (1psc)</li> <li>f. 135R.07.01.00 (1psc)</li> </ul>
3	1	Pipe holder	ST0018		<ul style="list-style-type: none"> <li>a. ST0018 (1psc)</li> <li>b. Washer DIN 125 M12 (2psc)</li> <li>c. Bolt DIN 912 M12x40 (1psc)</li> <li>d. Wing nut DIN 315 M10 (1psc)</li> <li>e. Washer DIN 125 M10 (1psc)</li> <li>f. Nut DIN 985 M12 (1psc)</li> <li>g. Bolt DIN 933 M10x30 (1psc)</li> </ul>
4	1	Hydraulics		See section "Hydraulics"	

5	1	Number plate	ST0016
---	---	--------------	--------



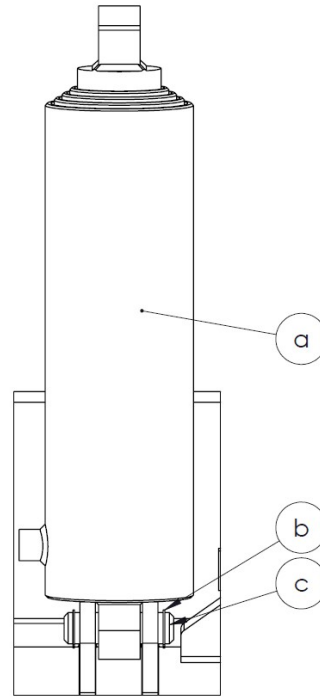
- a. Bolt DIN 933 M10x30 (4psc)
- b. Washer DIN 125 M10 (8psc)
- c. Nut DIN 985 M10 (4psc)
- d. Nut DIN 985 M6 (2psc)
- e. Washer DIN 125 M6 (2psc)
- f. ST0016 (1psc)
- g. Registration plate holder (1psc)
- g1. RP1 (without light)
- g2. RP2 (with light)
- h. Registration plate (not supplied by Ferrel AS)

6

2

Tilting  
cylinder

165R - NAS5  
195R - NAT6



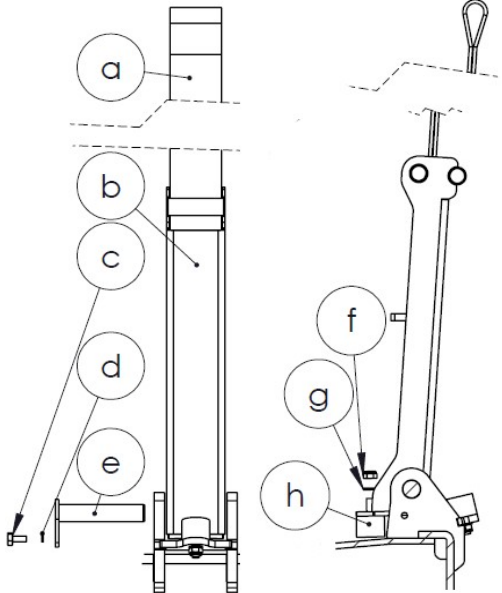
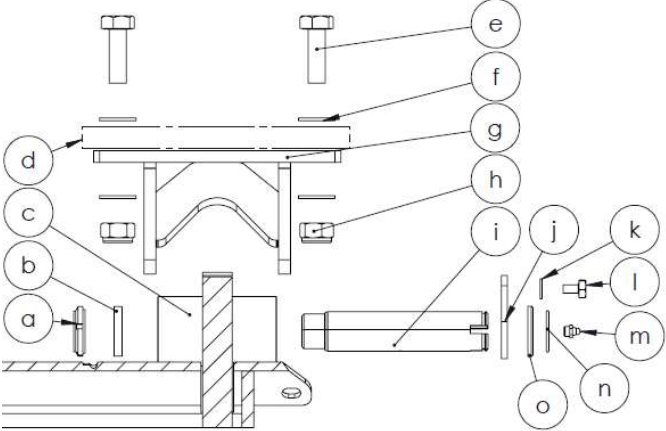
165R:

- a. NAS5 (1psc)
- b. ST0013 D30 L85 (1psc)
- c. Retaining ring DIN 471 D30 (2psc)

195R:

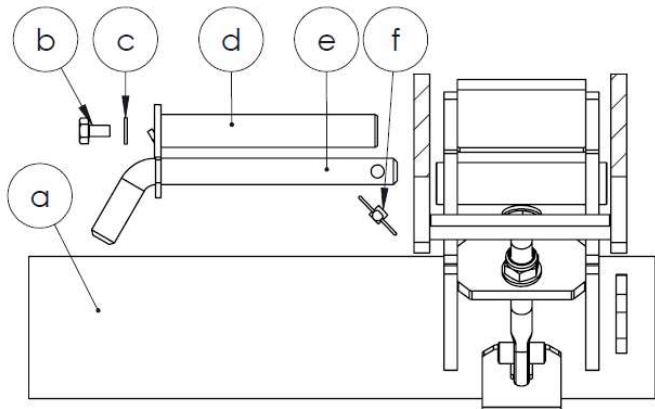
- d. NAT6 (1psc)
- e. ST0013 D30 L85 (1psc)
- Retaining ring DIN 471 D30 (2psc)



7	2	Tilting limiter	165R.08.00		<p>165R:</p> <ul style="list-style-type: none"> <li>a. OT0024_16H (1psc)</li> <li>b. 165R.08.00 (1psc)</li> <li>c. Bolt DIN 933 M10x20 (1psc)</li> <li>d. Washer DIN 125 M10 (1psc)</li> <li>e. ST.0003.00 25x125 (1psc)</li> <li>f. Nut DIN 985 M10 (2psc)</li> <li>g. Washer DIN 125 M10 (2psc)</li> <li>h. OT0028.01 D40_L30_M10 (2psc)</li> </ul> <p>195R:</p> <ul style="list-style-type: none"> <li>i. OT0024_195R (1psc)</li> <li>j. 165R.08.00 (1psc)</li> <li>k. Bolt DIN 933 M10x20 (1psc)</li> <li>l. Washer DIN 125 M10 (1psc)</li> <li>m. ST.0003.00 25x125 (1psc)</li> <li>n. Nut DIN 985 M10 (2psc)</li> <li>o. Washer DIN 125 M10 (2psc)</li> <li>p. OT0028.01 D40_L30_M10 (2psc)</li> </ul>
8a	2	Tilt flange Version "A"	FE00.02.00		<ul style="list-style-type: none"> <li>o. Nut CRN 35x1,5 (1psc)</li> <li>p. Collar ST0024.4 TS-35,5-40,5-50 (1psc)</li> <li>q. Frame 165R</li> <li>r. Box 165DH</li> <li>s. Bolt DIN 933 M20x55 (6psc)</li> <li>t. Washer DIN 6916 VH300 M20 (12psc)</li> <li>u. FE00.02.00 (1psc)</li> <li>v. Nut DIN 985 M20 (6psc)</li> <li>w. Pin ST0024.01 TLK 40-150 (1psc)</li> <li>x. Heel ST0024.01 TLK40 (1psc)</li> <li>y. Washer DIN 125 M10 (1psc)</li> <li>z. Bolt Din 933 M10x16 (1psc)</li> <li>aa. Grease nipple DIN 71412 M10x1 (1psc)</li> <li>bb. Stopper collar DIN7993 A D40 (1psc)</li> <li>cc. Collar ST0024.03 TLKV-40 (1psc)</li> </ul>

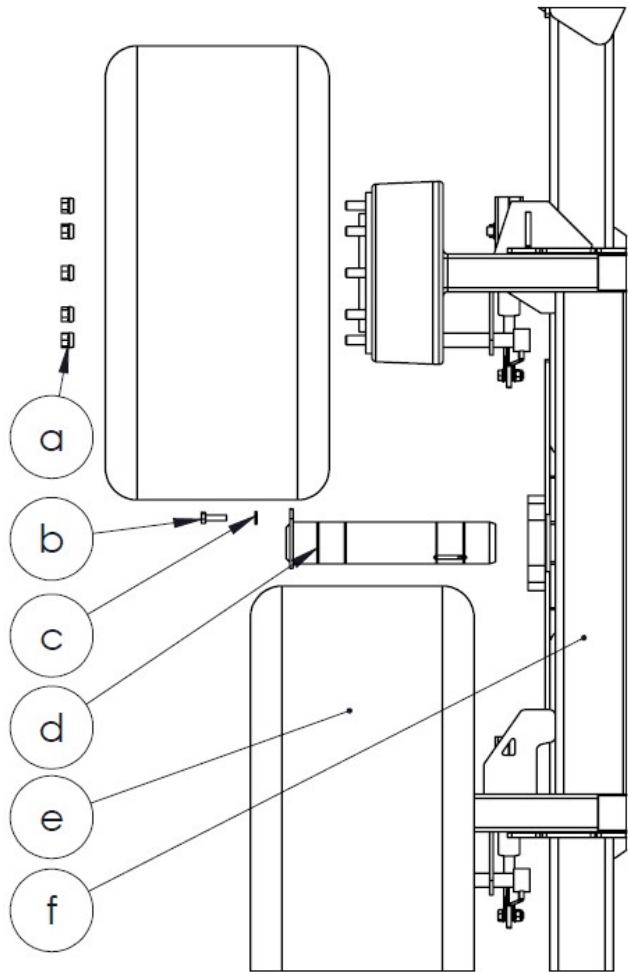
8b	2	Tilt flange Version "B"	FE00.02.00		<ul style="list-style-type: none"> <li>k. Frame 165R/195R</li> <li>l. Box 165DH</li> <li>m. Bolt DIN 933 M20x55 (6psc)</li> <li>n. Washer DIN 6916 VH300 M20 (12psc)</li> <li>o. FE00.02.00 (1psc)</li> <li>p. Plate FE00.02.00.02 (2psc)</li> <li>q. Nut DIN 985 M20 (6psc)</li> <li>r. Pin ST0004.00 40-150 (1psc)</li> <li>s. Grease nipple DIN 71412 M10x1 (1psc)</li> <li>t. Washer DIN 125 M10 (1psc)</li> <li>dd. Bolt Din 933 M10x16 (1psc)</li> </ul>
9	1+1 R+L	Rear light flange	FE00.04.01.00		<ul style="list-style-type: none"> <li>a. Bolt DIN 933 M12x40 (3psc)</li> <li>b. Nut DIN 985 M12 (2psc)</li> <li>c. FE00.04.01.00 (1 right hand + 1 left hand)</li> <li>d. Washer DIN 125 M12 (5psc)</li> </ul>

10	1	Rear guard	FE00.07.00
----	---	------------	------------

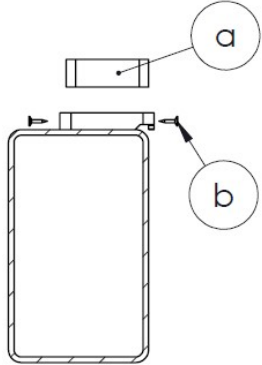
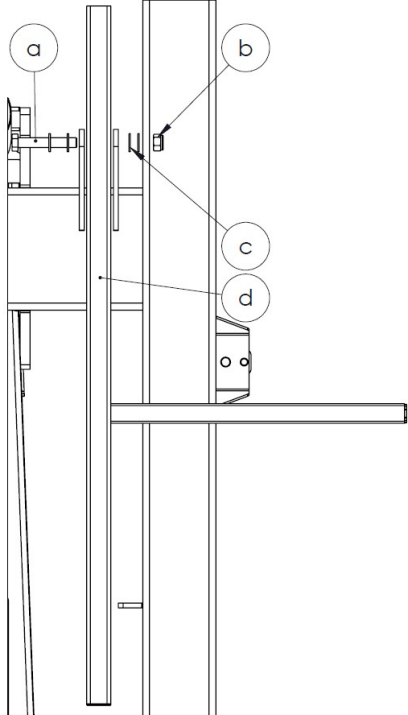


- a. FE00.07.00 (1psc)
- b. Bolt DIN 933 M10x16 (2psc)
- c. Washer DIN 125 M10 (2psc)
- d. ST.0003.00 25x165 (2psc)
- e. ST0001.00 D20x160 (2psc)
- f. Splint pin DIN 11023 D4,5 (1psc)

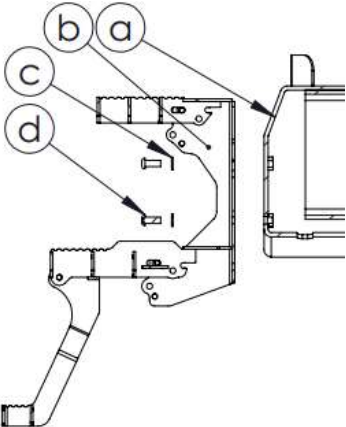
11	1+1 R+L	Bogie axle	165R.09.01.00 195R.09.01.00
----	------------	------------	--------------------------------



- 165R:**
- a. Wheel nut DIN 74361 M22 (2x10psc)
  - b. Bolt DIN 933 M16x50 (1psc)
  - c. Washer DIN 125 M16 (1psc)
  - d. ST0022.00; D100x500 (1psc)
  - e. Wheel with rim (2psc)
    - e1. W3 – 560/45 R22,5"
    - e2. W4 – 600/50 R22,5"
    - e3. W5 – 710/45 R22,5"
  - f. 165R.01.00 (1psc)
    - f1. H0 – no brakes
    - f2. H1 – 1 hydraulic brake
    - f3. H2 – 2 hydraulic brakes
    - f4. P1 – 1 Pneumatic brake
    - f5. P2 - 2 Pneumatic brake
    - f6. HP - 1 hydraulic + 1 Pneumatic brake
- 
- 195R:**
- a. Wheel nut DIN 74361 M22 (2x10psc)
  - b. Bolt DIN 933 M16x50 (1psc)
  - c. Washer DIN 125 M16 (1psc)
  - d. ST0022.00; D100x500 (1psc)
  - e. Wheel with rim (2psc)
    - e2. W4 – 600/50 R22,5"
    - e3. W5 – 710/45 R22,5"
  - f. 195R.01.00 (1psc)
    - f1. H0 – no brakes
    - f2. H1 – 1 hydraulic brake
    - f3. H2 – 2 hydraulic brakes
    - f4. P1 – 1 Pneumatic brake
    - f5. P2 - 2 Pneumatic brake
    - f6. HP - 1 hydraulic + 1 Pneumatic brake

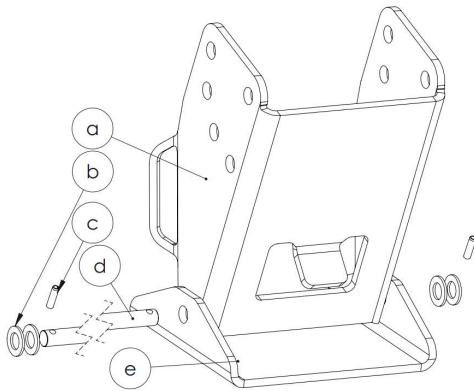
12	2	Plastic cushion 2	OT00011		<ul style="list-style-type: none"> <li>a. OT00011 140x90x25 (1psc)</li> <li>b. Screw D3 L20 (4psc)</li> </ul>
13	1	Box support	FE00.07.00		<ul style="list-style-type: none"> <li>a. Bolt DIN 933 M20 x120 (1psc)</li> <li>b. Nut DIN 985 M20 (1psc)</li> <li>c. Washer DIN 125 M20 (4psc)</li> <li>d. FE00.07.00 (1psc)</li> </ul>

14	1	Frame	165R.01.01.00 195R.01.01.00		
15	2	Plastic cushion 1	OT00011		a. OT00011 140x90x30 (1psc) b. Screw D3 L20 (4psc)
16	2	Chocks	OT0008.02		a. Bolt DIN 7500 D8x20 (4psc) b. OT0008.02

17	1	Steps	FE00.09.05.00.00		<ul style="list-style-type: none"> <li>a. Frame 135R.01.00.00</li> <li>b. Step FE00.09.05.00.00 (extended)</li> <li>c. Washer DIN 125 M12 (3pcs)</li> <li>d. Bolt DIN 7380 M12x30</li> </ul>
18	1	Handbrake	FE00.06.00.00	See section "Handbake"	

**Table 8.5.** - Components of frame 165R/195R

## 2. Components of parking stand

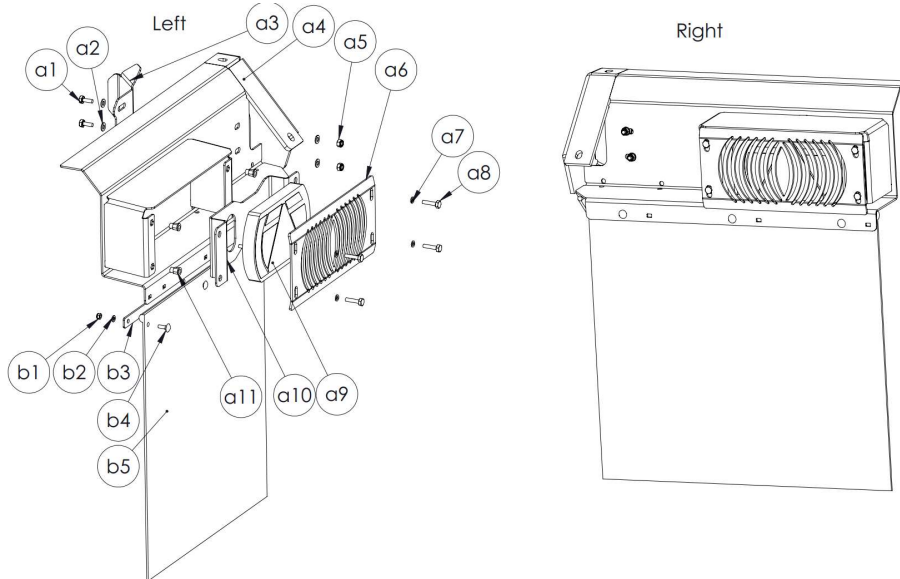


**Figure 8.5.1.** – Components of parking stand

Pos.	QTY	Part name	Part No	Description
a	1	Stand frame	135R.07.01.00	
b	4	Washer	DIN 125	M20
c	2	Splint pin	DIN 11023	D4,5
d	1	Round pin w. Cross hole	ST0012	D20_L330_2xd8_EL
e	1	Stand heel	135R.07.01.02	

**Table 8.5.1.** - Components of parking stand

## 3. Components of rear light frame



**Figure 8.5.2.** - Components of rear light frame

Pos.	QTY	Part name	Part No	Description
a1	6	Bolt	DIN 933	M8x20
a2	12	Washer	DIN 125	M8
a3	1	Wire guard	FE00.04.00.05	
a4	1	Frame	FE00.04.01.00	Left/Right
a5	6	Nut	DIN 985	M8
a6	1	Light protection	ST0015.03.00	

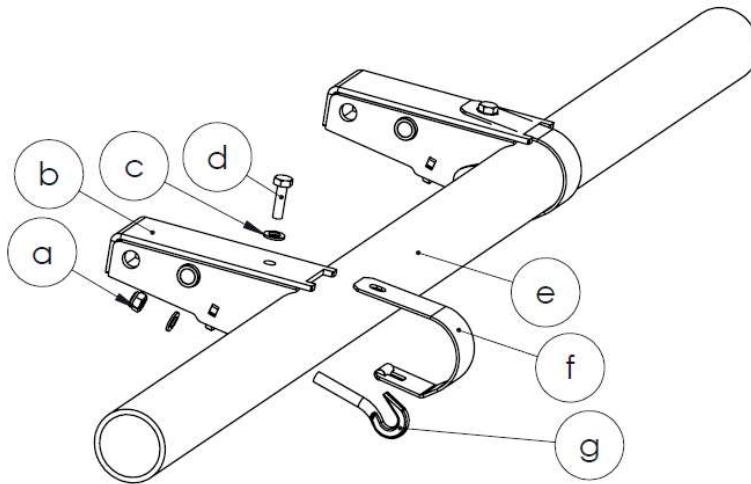


a7	8	Washer	DIN 125	M8
a8	4	Bolt	DIN 933	M8x30
a9	1	Rear light	OT0026.005	Left/right
a10	1	Light bracet	FE00.04.00.02	
a11	4	Rivet nut	MFX 23	M8
b1	3	Nut	DIN 985	M6
b2	6	Washer	DIN 125	M6
b3	1	Flap strip	FE00.04.00.01	
b4	3	Bolt	DIN 603	M6x20
b5	1	Mud flap	OT0020	Width: 165R – 620mm

a- Base model; b- light protection (accessory); c – Mud flap (accessory)

**Table 8.5.2.** - Components of rear light frame

4. Components of rear guard

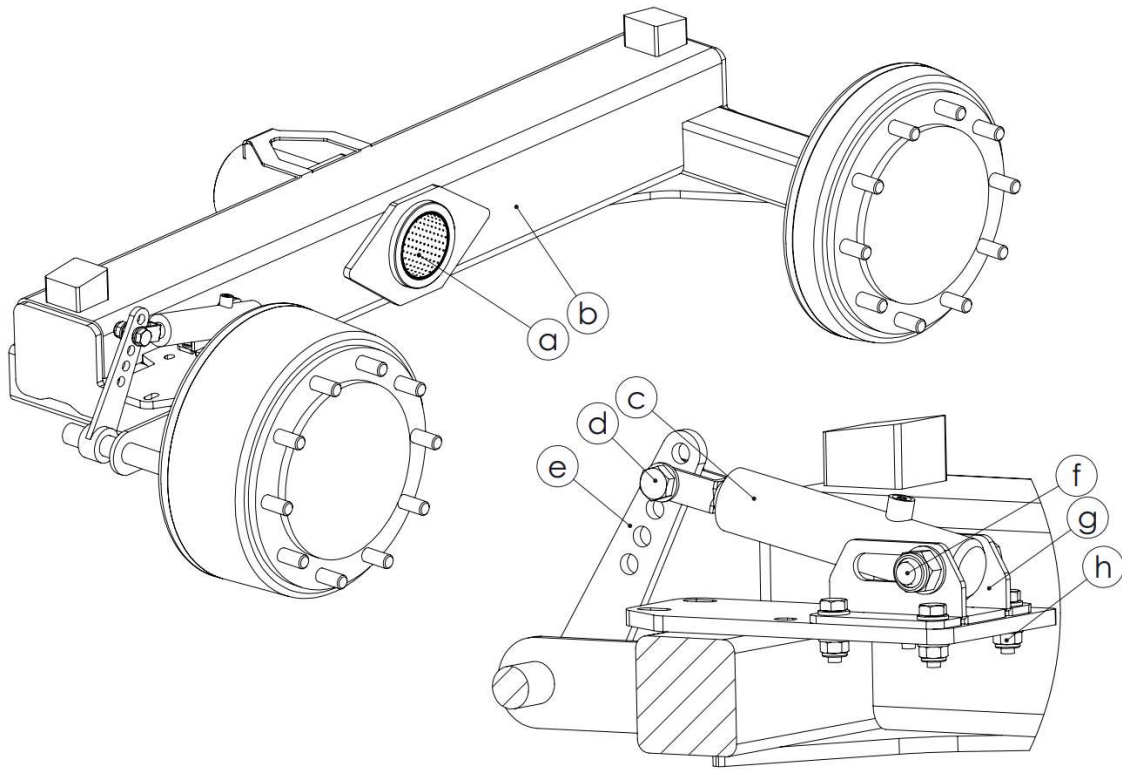


**Figure 8.5.3.** Components of rear guard

Pos.	QTY	Part name	Part No	Description
a	4	Nut	DIN 985	M16
b	2	Frame for rear guard	FE00.07.01.00	
c	4	Washer	DIN 125	M16
d	2	Bolt	DIN 933	M16x50
e	1	Rear guard	FE00.07.03.01	
f	2	Strap	FE00.07.02.00	
g	2	Hook bolt	G-hook	M16

**Table 8.5.3.** - Components of rear guard

## 5. Components of bogie



**Figure 8.5.4.** – Components of bogie – hydraulic brakes

Pos.	QTY	Part name	Drawing No. 165DH	Drawing No. 195DH	Description
a	2	Slide bearing	100x105 L100	100x105 L100	
b	1	Bogie	165R.09.01.00	195R.09.01.00	H0 – no brakes H1VP/PP – one brake; left/right H2VP/PP – two brakes; left/right
c	1	Brake cylinder	CY.01.00	CY.01.00	
d	1	Bolt ass.	DIN 933 M16x50 (1pcs) DIN 125 M16 (2pcs) DIN 985 M16 (1pcs)	DIN 933 M16x50 DIN 125 M16 (2pcs) DIN 985 M16 (1pcs)	
e	1	Brake lever	S90TN1TG013	S90TN1TG013	
f	1	Bolt ass.	DIN 933 M20x100 (1pcs) DIN 125 M20 (2pcs) DIN 985 M20 (1pcs)	DIN 933 M20x100 (1pcs) DIN 125 M20 (2pcs) DIN 985 M20 (1pcs)	
g	1	H. cylinder stand	165R.09.03.00	165R.09.03.00	
h	4	Bolt ass.	DIN 933 M12x40 (1pcs) DIN 125 M12 (2pcs) DIN 985 M12 (1pcs)	DIN 933 M12x40 (1pcs) DIN 125 M12 (2pcs) DIN 985 M12 (1pcs)	

**Table 8.5.4.1.** - Components of bogie

## Components of stub axles

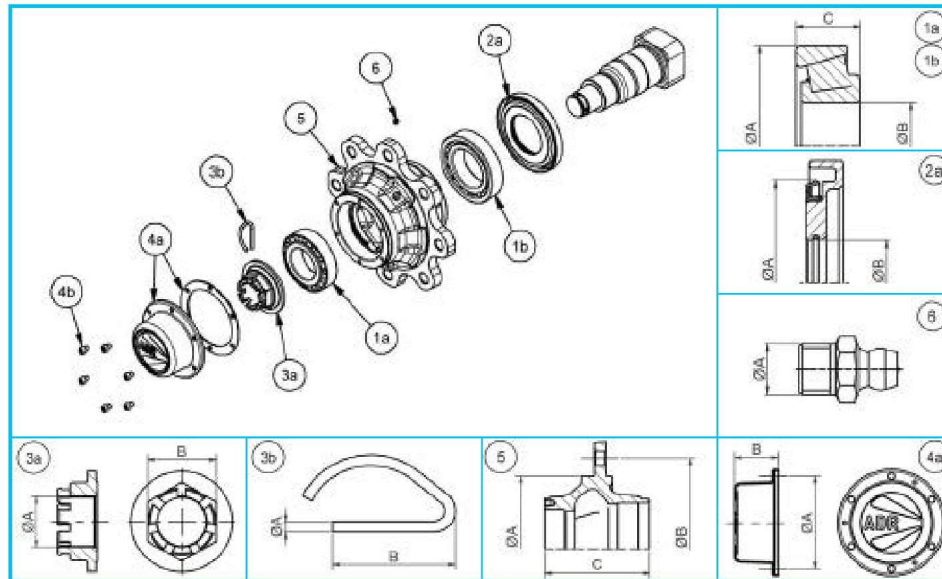
Additional information about ADR axle spare parts:

<http://www.adraxles.com/EN/res/429/ADR---Spare-Parts-Catalogue.pdf>

TR type -



Axle type - TR -



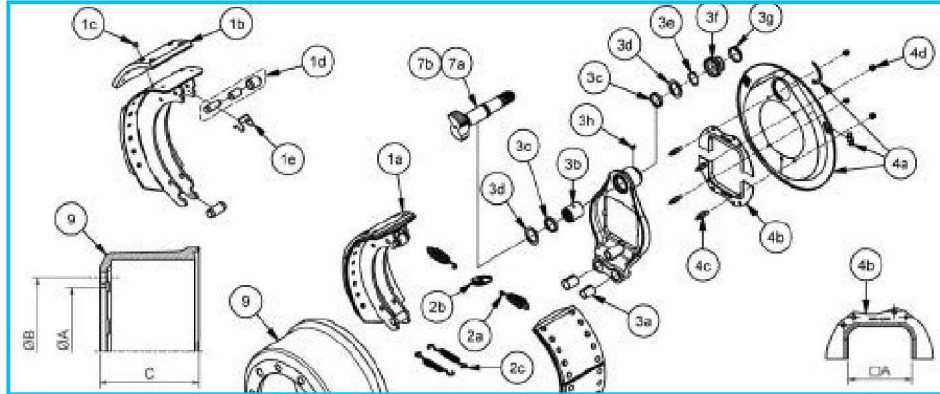
Item	Description	Code	A	B	C	Qty.	Kit code
1a	Bearing 32213	59132213	120	65	32,75	1	9RCTC
1b	Bearing 32216	59132216	140	80	35,25	1	
2a	Oil seal	5471403	140	82	-	1	9RNTR
3a	Crown nut	57548B6	M48X1,5	65	-	2	9RDF4865
3b	Spring pin	58209	5	58	-	2	
4a	Cap with gasket	56112518	139	62	-	2	9RT125AC
4b	Screw M8X1,25	96308A0101	-	-	-	12	
5	Hub 8 holes for M20X1,5	61L8TD004	220	275	160	1	61L8TD004
	Hub 10 holes for M22X1,5	61L1TD003	280	335	160	1	61L1TD003
6	Grease nipple	98608A1	M8X1,25	-	-	50	9R98608A1

VC type -

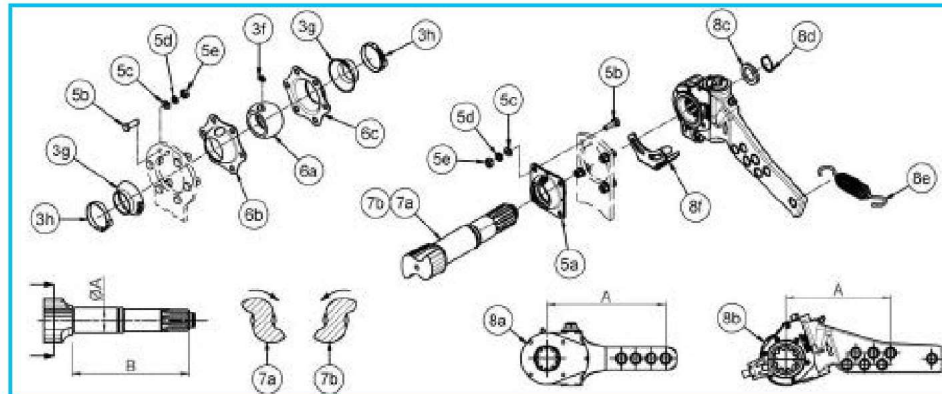


**Brake 406X120 - 412E - VC**

(page 1 of 2)



Item	Description	Code	A	B	C	Qty.	Kit code
1a	Brake shoe complete	732VC03	-	-	-	2	9RE0092
2a	Spring Ø5,2 L106	738128	-	-	-	2	
2b	Twist lock	736XC02	-	-	-	1	
2c	Spring Ø3,0 L138	738129	-	-	-	2	
3a	Bush Ø28/32 L40	771008	-	-	-	2	9RH0034
1b	Brake lining	734VC02	-	-	-	4	
2a	Spring Ø5,2 L106	738128	-	-	-	2	
2b	Twist lock	736XC02	-	-	-	1	
2c	Spring Ø3,0 L138	738129	-	-	-	2	9RK0016
1c	Rivet	96701	-	-	-	34	
2a	Spring Ø5,2 L106	738128	-	-	-	4	
2b	Twist lock	736XC02	-	-	-	2	
2c	Spring Ø3,0 L138	738129	-	-	-	4	9RE0084
1d	Roll Ø32	73BVC01	-	-	-	2	
1e	Spring	738127	-	-	-	2	
3a	Bush Ø28/32 L40	771008	-	-	-	2	
3b	Camshaft bush Ø42	771007	-	-	-	1	
3c	Seal Ø42	5490501	-	-	-	2	
3d	Washer Ø42	73G01	-	-	-	2	
3e	Retaining ring Ø42	58514	-	-	-	1	
3f	Rubber cover	53A11	-	-	-	1	
3g	Clamp	98E01	-	-	-	1	
3h	Grease nipple M8X1,25	98608A1	-	-	-	1	
4a	Protection plate with rubber caps	743WC0006	-	-	-	1	9RM061
4b	Square seal	747A012	90	-	-	2	
4c	Spacer L51	57708A1	-	-	-	4	
4d	Nut M8X1,25	97708A1	-	-	-	4	
4a	Protection plate with rubber caps	743WC0006	-	-	-	1	9RM062
4b	Square seal	747A012	100	-	-	2	
4c	Spacer L51	57708A1	-	-	-	4	
4d	Nut M8X1,25	97708A1	-	-	-	4	
4a	Protection plate with rubber caps	743WC0006	-	-	-	1	9RM038
4b	Square seal	747A112	110	-	-	2	
4c	Spacer L51	57708A1	-	-	-	4	
4d	Nut M8X1,25	97708A1	-	-	-	4	
4a	Protection plate with rubber caps	743WC0006	-	-	-	1	9RM040
4b	Square seal	747A242	120	-	-	2	
4c	Spacer L51	57708A1	-	-	-	4	
4d	Nut M8X1,25	97708A1	-	-	-	4	
4a	Protection plate with rubber caps	743WC0006	-	-	-	1	9RM042
4b	Square seal	747A342	130	-	-	2	
4c	Spacer L51	57708A1	-	-	-	4	
4d	Nut M8X1,25	97708A1	-	-	-	4	
4a	Protection plate with rubber caps	743WC0006	-	-	-	1	9RM044
4b	Square seal	747A542	150	-	-	2	
4c	Spacer L51	57708A1	-	-	-	4	
4d	Nut M8X1,25	97708A1	-	-	-	4	



Item	Description	Code	A	B	C	Qty.	Kit code
4a + 4b	Protection plate with rubber caps	743WCR222	Ø127	-	-	1	9RM046
4c	Spacer L38	57708A2	-	-	-	4	
4d	Nut M8X1,25	97708A1	-	-	-	4	
5a	Camshaft bush assembled	74417U01	-	-	-	1	
5b	Screw M8X1,25 L25	96108A0251	-	-	-	4	9RL010
5c	Washer Ø8	9810081	-	-	-	4	
5d	Elastic washer Ø8	9830081	-	-	-	4	
5e	Nut M8X1,25	97108A1	-	-	-	4	
6a	Camshaft bush Ø39	772007	-	-	-	1	(2) 9RL001
6b	Casing	7480401	-	-	-	1	
6c	Casing	7480402	-	-	-	1	
6d	Rubber cover	56A10	-	-	-	2	
3g	Clamp	98E01	-	-	-	2	
3h	Grease nipple M8X1,25	98608A1	-	-	-	1	
5b	Screw M8X1,25 L25	96108A0251	-	-	-	6	
5c	Washer Ø8	9810081	-	-	-	6	
5d	Elastic washer Ø8	9830081	-	-	-	6	
5e	Nut M8X1,25	97108A1	-	-	-	6	
7a	Right camshaft	75P4062...	42	(1) <=300	-	1	75P4062...
	Right camshaft	75P4063...	42	(1) >300	-	1	75P4063...
7b	Left camshaft	75Q4062...	42	(1) <=300	-	1	75Q4062...
	Left camshaft	75Q4063...	42	(1) >300	-	1	75Q4063...
8a	Slack adjuster	7621603	203	-	-	1	9RR0010
8c	Washer Ø26	9812601	-	-	-	1	
8d	Retaining ring Ø25	58508	-	-	-	1	
8e	Spring Ø3,5 L173	738201	-	-	-	1	
8b	Automatic slack adjuster	7631606	180	-	-	1	9RS0018
8c	Washer Ø26	9812601	-	-	-	1	
8d	Retaining ring Ø25	58508	-	-	-	1	
8e	Spring Ø2,8 L145	738203	-	-	-	1	
8f	Setting plate	76A12	-	-	-	1	
5b	Screw M8X1,25 L25	96108A0251	-	-	-	2	
5c	Washer Ø8	9810081	-	-	-	2	
5d	Elastic washer Ø8	9830081	-	-	-	2	
5e	Nut M8X1,25	97108A1	-	-	-	2	
g	Drum 10 holes for M22X1,5	66LVA1006	280	335	165	1	66LVA1006
	Drum 10 holes for M22X1,5	66LVA1008	290	335	165	1	66LVA1008

(1) - From 200mm to 300mm step 25mm. From 300mm to 1200mm step 50mm.  
 (2) - For axles produced till 2013.

Figure 8.5.4.2. Components of stub axle

## 6. Components of steps

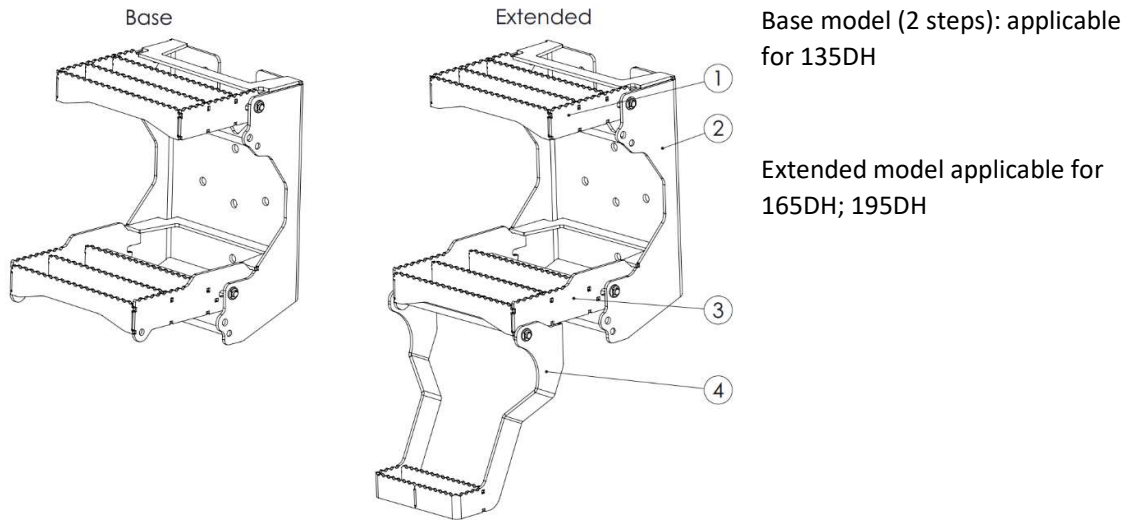


Figure 8.5.5.1. Components of steps

Pos.	QTY	Part name	Drawing No.	Assembly drawing	Components
1	1	Top step	FE00.09.05.01.00		a. Step: (1pcs) <ul style="list-style-type: none"> <li>• FE00.09.05.01.00</li> <li>• FE00.09.05.02.00</li> <li>• FE00.09.05.03.00</li> </ul>
2	1	Frame	FE00.09.05.04.00		b. Frame 09.05.04.00 (1pcs)
3	1	Bottom step	FE00.09.05.03.00		c. Washer DIN 125 M10 (4pcs) d. Pin ST0013 D10L300 (1pcs)
4	1	Extension	FE00.09.05.02.00		e. Retaining ring DIN 6799 D10 (2pcs)

Table 8.5.5. Components of steps

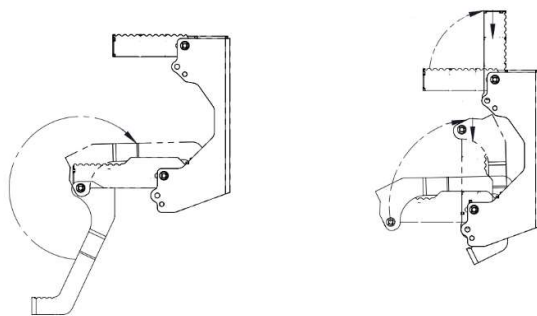


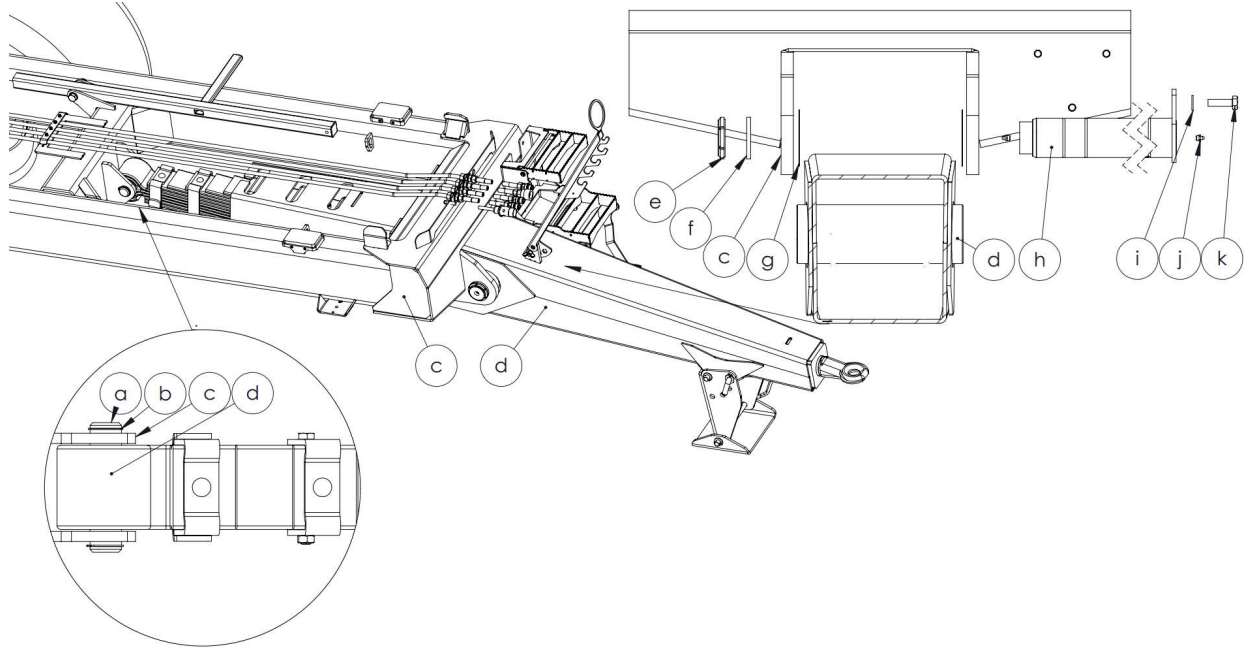
Figure 8.5.5.2. Folding of steps

Steps are foldable for better fit when driving:

1. Fold extension on top of bottom step
2. Lift top and bottom step up 90 degrees and drop until they lock.

## 6. Spring suspension drawbar

### 1. Frame assembly 165R.03.00.00/195R.03.00.00

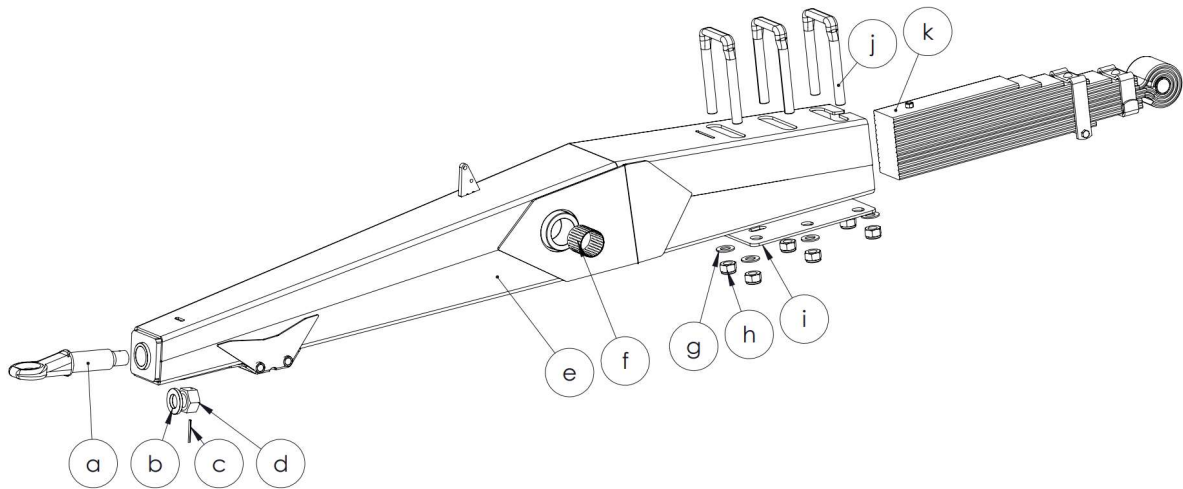


**Figure 8.6.1.** Spring suspension drawbar assembly

Pos.	QTY	Part name	Drawing No. 165R/195R
a	1	Pin	ST0013 D45L165
b	2	Retaining ring	DIN 471 D45
c	1	Frame	165R.03.01.00/ 195R.03.01.00
d	1	Spring suspension pack	OT0048.01
e	1	Axle nut	CRN65x2
f	1	Axle collar	ST0024.04 TS-65
g	2	Washer	ST0030.01 D82x1,5
h	1	Pin	ST0025.00 D80x415
i	1	Washer	DIN 125 M16
j	2	Grease nipple	M10x1
k	1	Bolt	M16x50

**Table 8.6.1** Spring drawbar main assembly

## 2. Spring suspension components



**Figure 8.6.2** Components of spring suspension drawbar

Pos.	QTY	Part name	Drawing No. 165R/195R
a	1	Towing eye	HS17T-02
b	1	Washer	HS17T-04
c	1	Splint pin	DIN 1481 D6 L70
d	1	Nut	DIN 24032 M42
e	1	Drawbar	165R.03.02.00
f	2	Slide bearing	D80 L80
g	6	Washer	DIN 125 M30
h	6	Nut	DIN 985 M30x2
i	1	Base plate	165R.03.00.01
j	3	U-bolt	M30x2
k	1	Bolt	M16x50

**Table 8.6.2** Components of spring suspension drawbar



7. Components of DH box

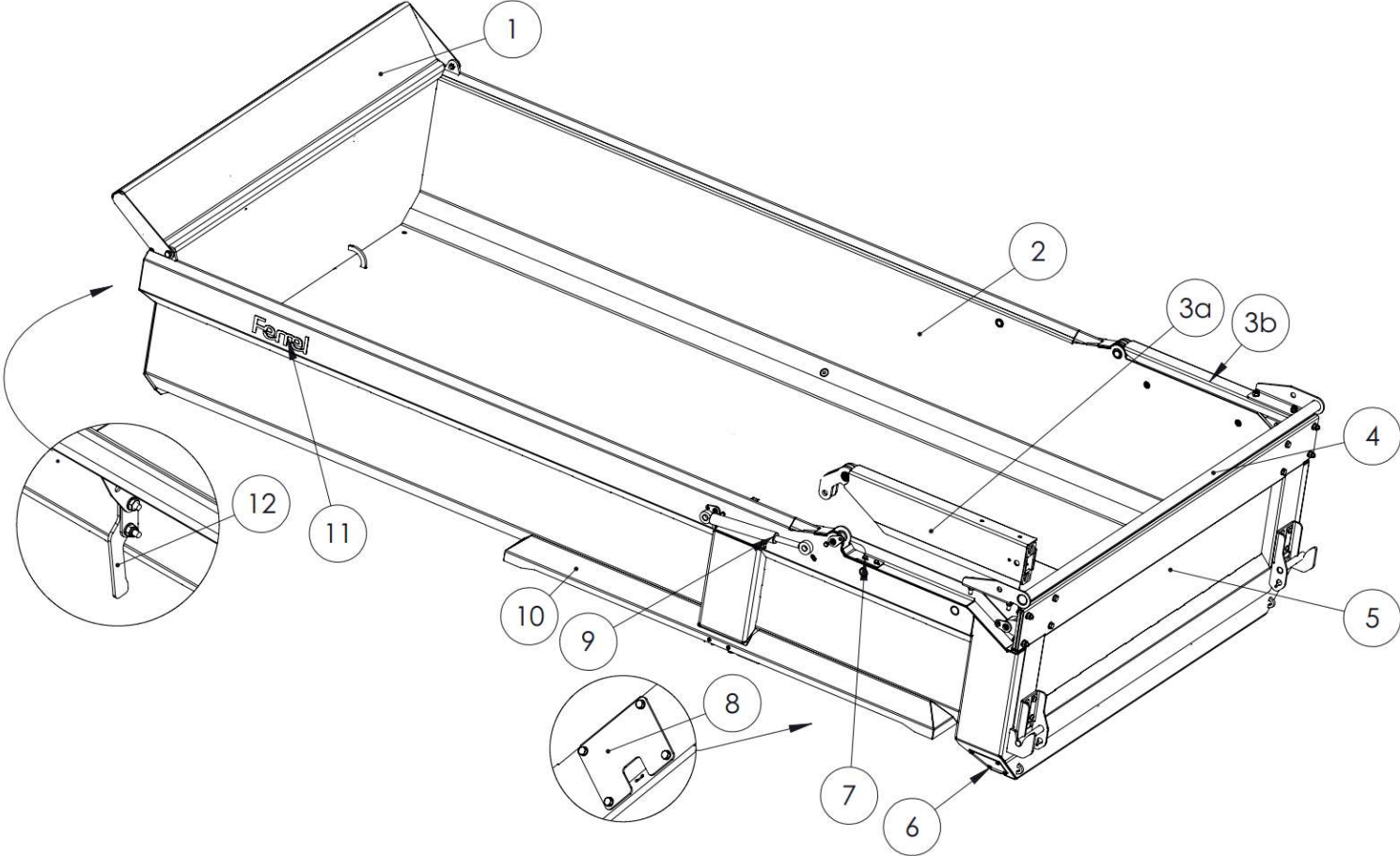
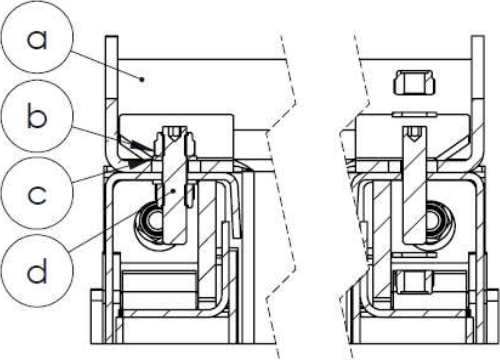
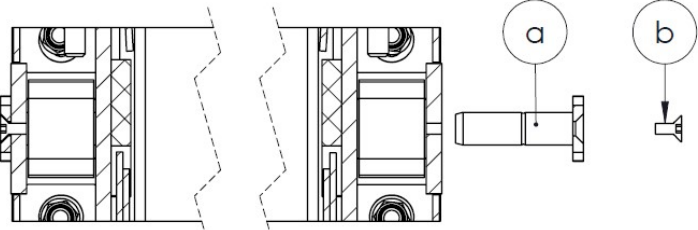
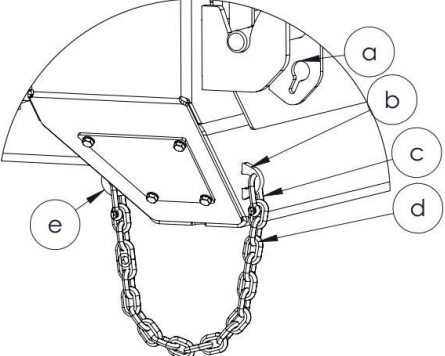
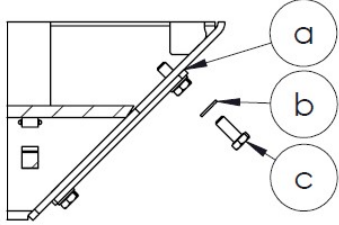
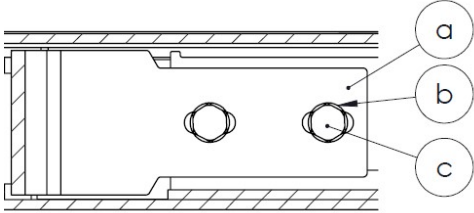
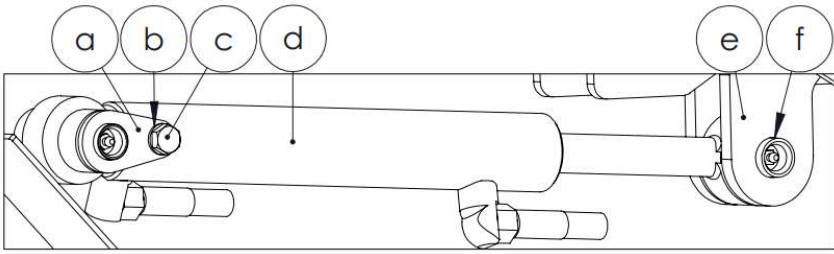
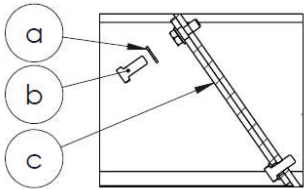
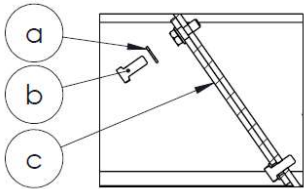
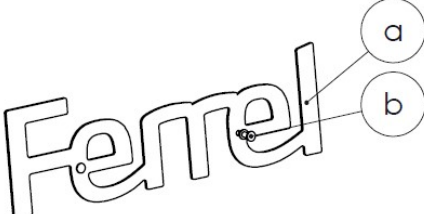
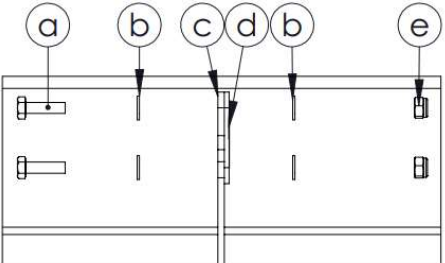


Figure 8.7. – Components of DH box

Pos.	QTY	Part name	Part No	Assembly drawing	Components
1	1	Front cover	FE00.03.00		<ul style="list-style-type: none"> <li>a. FE00.03.00 (1psc)</li> <li>b. Bolt – DIN 933 M16x50 (4psc)</li> <li>c. Washer – DIN 125 M16 (8psc)</li> <li>d. Nut – DIN 985 M16 (4psc)</li> </ul>
2	1	Main box	135DH.01.00.00 165DH.01.00.00 195DH.01.00.00		
3a 3b	1+1	Lifting arm	135DH - 135DH.04.01.00  165DH/ 195DH - 165DH.04.01.00		<ul style="list-style-type: none"> <li>a. ST0004.00 – D30x90 (1psc)</li> <li>b. Washer – DIN 125 M12 (1psc)</li> <li>c. Bolt – DIN 933 M12x20 (M12)</li> </ul>

4	1	Torsion bar	135DH.04.05.00		<ul style="list-style-type: none"> <li>a. 135DH.04.05.00 (1psc)</li> <li>b. Nut – DIN 985 M16 (8psc)</li> <li>c. Washer – DIN 125 M16 (8psc)</li> <li>d. Bolt DIN 913 M16x80 (M4)</li> </ul>
5	1	Rear hatch	135DH.04.00.00 165DH.04.00.00 195DH.04.00.00		<ul style="list-style-type: none"> <li>a. ST0020.01 D25 (1psc)</li> <li>b. Bolt DIN 7991 M10x20 (1psc)</li> </ul>
6	2	Limiting chain	ST0021.00		<ul style="list-style-type: none"> <li>a. Rear hatch (top limiting point)</li> <li>b. DH box (anchoring point)</li> <li>c. D-shackle d8 (2psc)</li> <li>d. Limiting chain DIN766 d8 (25 links)</li> <li>e. DH box (resting point)</li> </ul>

7	2	Side service hatch	ST0029.02		a. ST0029.02– 1psc b. Washer DIN 125 M8 (4psc) c. Bolt DIN 933 M8x20 (4psc)
8	2	Swiper	135DH.05.01.01		a. 135DH.05.01.01 (1psc) b. Washer DIN 125 M10 (2psc) c. Bolt DIN 933 M10x20 (2psc)
9	2	Lifting cylinder	HC-40-25-313_DH		a. Pin ST0004.00 D25 L85 (1psc) b. Washer DIN 125 M10 (1psc) c. Bolt DIN 933 M10x20 (1psc) d. Cylinder HC-40-25-313_DH (1psc) e. Lifting arm: (1psc) <ul style="list-style-type: none"> <li>• 135DH – 135DH.04.01.00</li> <li>• 165DH/195DH – 165DH.04.01.00</li> </ul> f. Pin ST0004.03 D25 L67 (1psc)
10	1	Center service hatch	ST0029.01		a. Washer DIN 125 M8 (4psc) b. Bolt DIN 933 M8x20 (4psc) c. ST0029.01 (1psc)
11	2	Mudguards	135DH.05.08.00 165DH.05.08.00		a. Washer DIN 125 M12 (2 psc) b. Bolt DIN 7380 M12x25 (2psc) c. Mudguard (1psc) <ul style="list-style-type: none"> <li>• 135DH - 135DH.05.08.00</li> <li>• 165DH - 165DH.05.08.00</li> </ul>

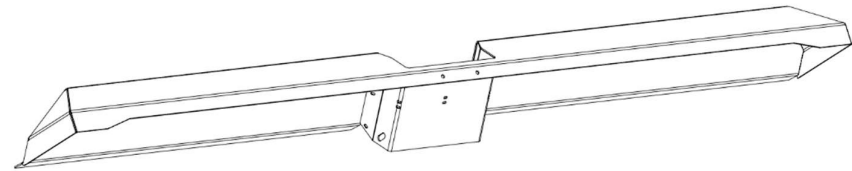
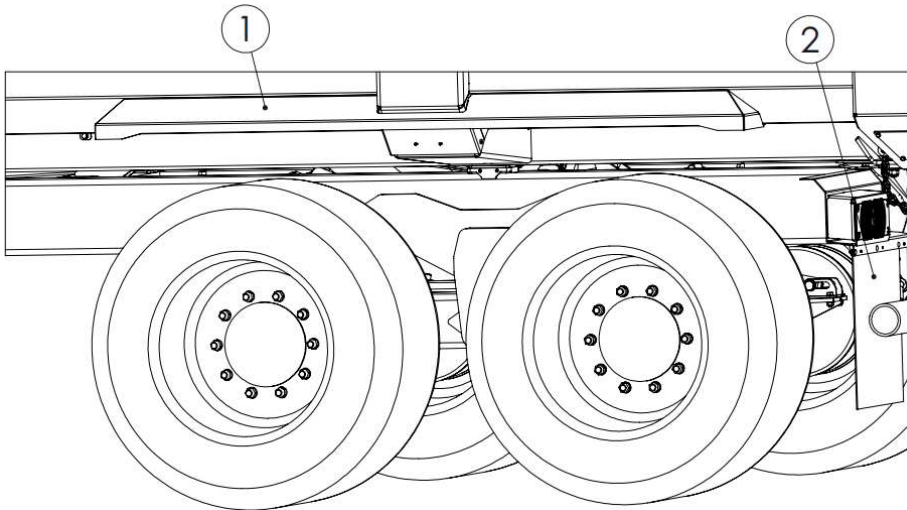
						<ul style="list-style-type: none"> <li>d. Bolt DIN 7380 M10x20 (4psc)</li> <li>e. Washer DIN 125 M10 (4psc)</li> <li>f. Setup plate 135DH.05.08.06 (if required)</li> </ul>
11	2					g.
12	2	Logo	ST0002			<ul style="list-style-type: none"> <li>a. ST0002 (1psc)</li> <li>b. Pull rivet D4 L14 (2psc)</li> </ul>
13	1	Handle	FE00.11.01.01			<ul style="list-style-type: none"> <li>a. Bolt DIN 933 M16x50 (2pcs)</li> <li>b. Washer DIN 125 M16 (4pcs)</li> <li>c. Handle FE00.11.01.01 (1psc)</li> <li>d. DH box</li> <li>e. Nut DIN 985 M16 (2pcs)</li> </ul>

**Table 8.7.** - Components of DH box 135DH/165DH/195DH

## 8. Mudguards and mudflaps

DH trailers have optional mudguards attachable to the box. The design of the mudguards depends on the model of the trailer and presence of side lamps. Optional mudflaps can be added on rear light frame and depending on model and equipment also on mudguard on trailer box.

### 1. Basic mudguard and mudflaps



Basic mudguards prevent substance from the wheels to be thrown upwards and sideways keeping others safe in traffic.

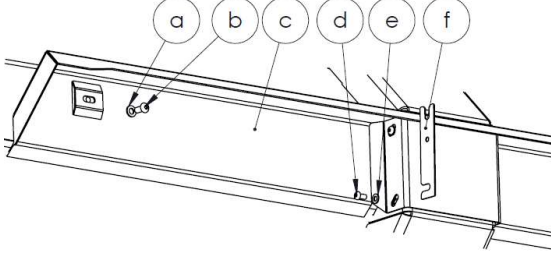
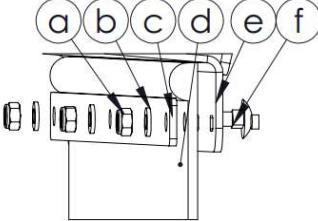
135DH basic mudguard can hold a sidelamp as an option.

Basic mudguards do not comply to EN 167 regulations.

Rear mudflap can be attached separately to the rear light frame.

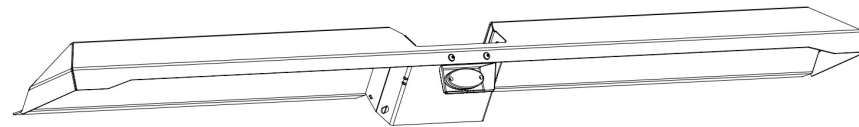
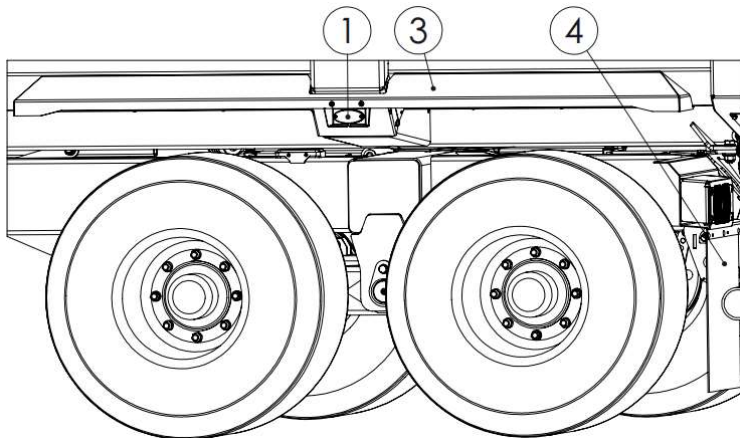
**Figure 8.8.1.**– DH trailer basic mudguard and rear mudflap

Pos.	QTY.	Part name	Drawing No. 135DH	Drawing No. 165DH/195DH	Description	Components
1	2	Basic mudguard	135DH.05.08.00	165DH.05.08.00		a. Washer DIN 125 M12 (2 psc) b. Bolt DIN 7380 M12x25 (2psc) c. Mudguard (1psc) <ul style="list-style-type: none"> <li>• 135DH - 135DH.05.08.00</li> <li>• 165DH - 165DH.05.08.00</li> </ul>

						<ul style="list-style-type: none"> <li>d. Bolt DIN 7380 M10x20 (4psc)</li> <li>e. Washer DIN 125 M10 (4psc)</li> <li>f. Setup plate 135DH.05.08.06 (if required)</li> </ul>
2	2	Mudflap (Optional)	OT0020 500mm	OT0020 620mm		<ul style="list-style-type: none"> <li>a. Nut DIN 985 M6 (3pcs)</li> <li>b. Washer DIN 125 M6 (3pcs)</li> <li>c. Crossbar FE00.04.00.01 (1pcs)</li> <li>d. Mudflap OT0020 (1pcs)</li> <li>e. Rear light frame FE00.04.01.00 (1pcs)</li> <li>f. Bolt DIN 603 M6x20 (3pcs)</li> </ul>

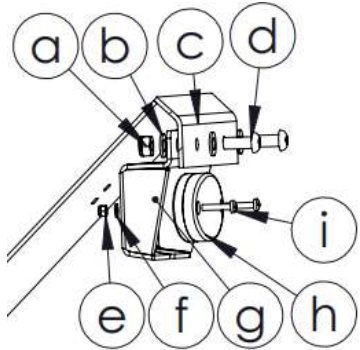
**Table 8.8.1** components of basic mudguards

2. 135DH mudguards with lights and mudflaps



135DH: Same as 135DH basic mudguards with sidelamp attached.

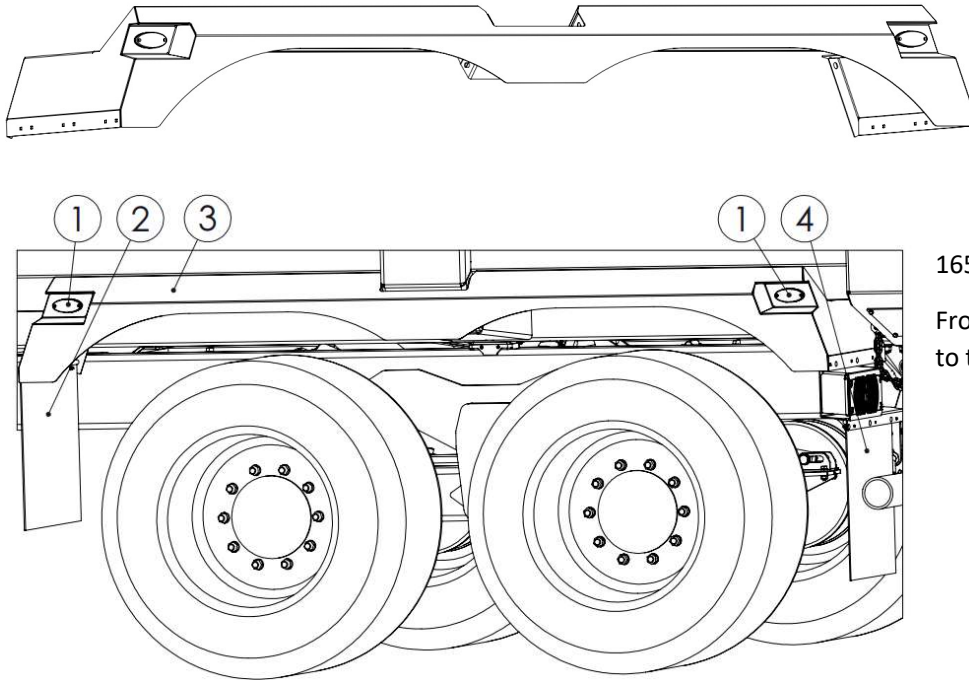
**Figure 8.8.2** – 135 DH trailer basic mudguard with side light

Pos.	QTY.	Part name	Drawing No. 135DH	Description	Components
1	1	Light flange	135DH.05.08.07		<ul style="list-style-type: none"> <li>a. Nut DIN 985 M8 (2pcs)</li> <li>b. Washer DIN 125 M8 (4pcs)</li> <li>c. Mudguard 135DH.05.08.00 (1pcs)</li> <li>d. Bolt DIN 7380 M8x20 (2pcs)</li> <li>e. Nut DIN 985 M4 (4pcs)</li> <li>f. Washer DIN 125 M4 (2pcs)</li> <li>g. Light flange 135DH.05.08.07 (1pcs)</li> <li>h. Side light OT0026.002 (1pcs)</li> <li>i. Screw DIN 7045 M4x20 (2pcs)</li> </ul>
3	2	Basic mudguard	135DH.05.08.00	See section "Basic mudguard and mudflaps"	See section "Basic mudguard and mudflaps"
4	2	Mudflap (Optional)	OT0020 500mm	See section "Basic mudguard and mudflaps"	See section "Basic mudguard and mudflaps"

**Table 8.8.2**– 135 DH trailer basic mudguard with side light



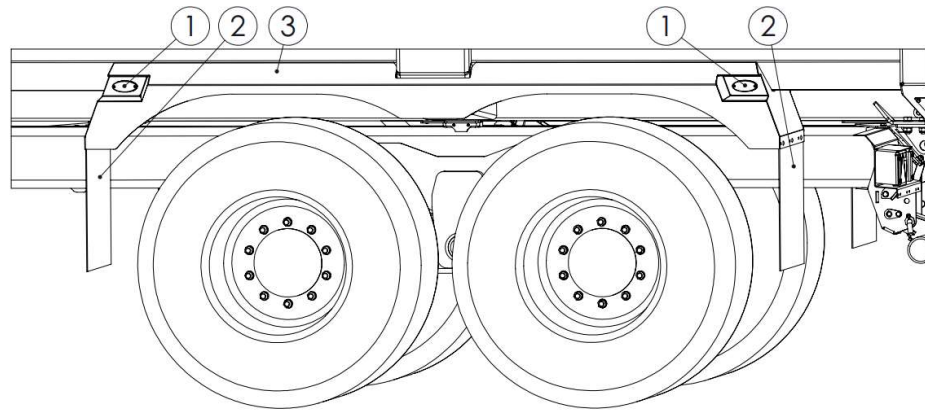
3. 165DH/195DH advanced mudguards with lights and mudflaps  
Advanced mudguards come with sidelamps. Mudflaps are optional.



165DH:

Front mudflap can be attached to the mudguard whilst rear mudflap goes to the rear light frame.

**Figure 8.8.3.1** 165DH advanced mudguards

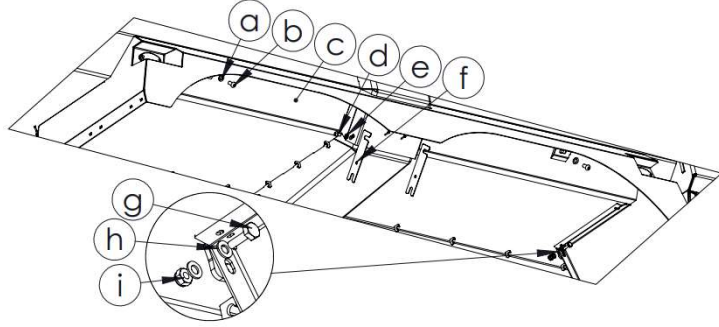
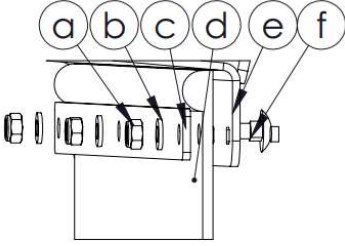


195DH

Both front and rear mudflap can be attached to the mudguard.

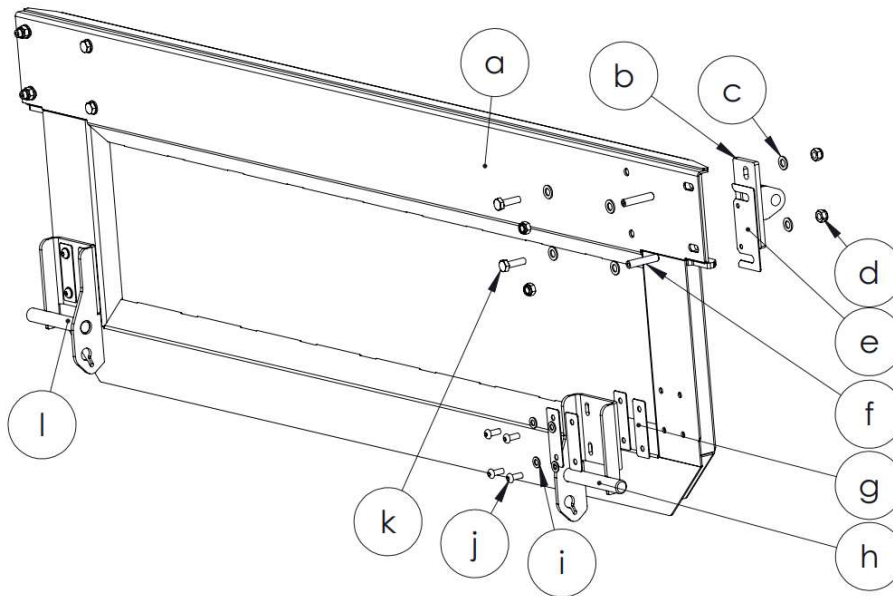
Figure 8.8.3.2 195DH advanced mudguards

Pos.	QTY.	Part name	Drawing No. 165DH/195DH	Description	Components
1	2	Side lamp	OT0026.002		<ul style="list-style-type: none"> <li>a. Screw DIN 7045 M4x20 (2pcs)</li> <li>b. Side light OT0026.002 (1pcs)</li> <li>c. Washer DIN 125 M4 (2pcs)</li> <li>d. Nut DIN 985 M4 (4pcs)</li> </ul>
2	165DH – 1pcs 195DH – 2pcs	Mudflap	OT0020		<ul style="list-style-type: none"> <li>a. Bolt DIN 603 M6x20 (3pcs)</li> <li>b. Advanced mudguard 195DH.05.08.00 (1pcs)</li> <li>c. Mudflap OT0020 (1pcs)</li> <li>d. Crossbar FE00.04.00.01 (1pcs)</li> <li>e. Washer DIN 125 M6 (3pcs)</li> <li>f. Nut DIN 985 M6 (3pcs)</li> </ul>

3	2	Advanced mudguard	195DH.05.08.00		<ul style="list-style-type: none"> <li>a. Washer DIN 125 M12 (2 pcs)</li> <li>b. Bolt DIN 7380 M12x25 (2psc)</li> <li>c. Advanced mudguard 195DH.05.08.00 (1psc)</li> <li>d. Bolt DIN 7380 M10x20 (4psc)</li> <li>e. Washer DIN 125 M10 (4psc)</li> <li>f. Setup plate 135DH.05.08.06 (if required)</li> <li>g. Bolt DIN 933 M10x30 (2pcs)</li> <li>h. Washer DIN 125 M10 (4pcs)</li> <li>i. Nut DIN 985 M10 (2pcs)</li> </ul>
4	165DH – 1pcs 195DH – 0pcs	Mudflap (Optional)	OT0020 620mm		<ul style="list-style-type: none"> <li>a. Nut DIN 985 M6 (3pcs)</li> <li>b. Washer DIN 125 M6 (3pcs)</li> <li>c. Crossbar FE00.04.00.01 (1pcs)</li> <li>d. Mudflap OT0020 (1pcs)</li> <li>e. Rear light frame FE00.04.01.00 (1pcs)</li> <li>f. Bolt DIN 603 M6x20 (3pcs)</li> </ul>

**Table 8.8.3.** 165DH/195DH advanced mudguards

## 9. Components of rear hatch

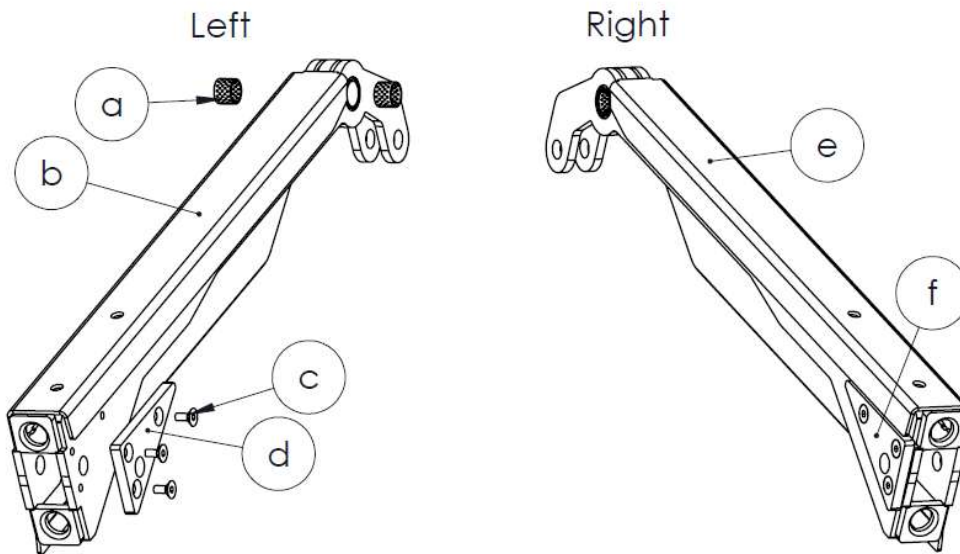


**Figure 8.9.** – Components of rear hatch 135DH.04.00.00/ 165DH.04.00.00/195DH.04.00.00

Pos.	QTY.	Part name	Drawing No. 135DH	Description
a	1	Hydraulic rear hatch	135DH.04.01.00 165DH.04.01.00 195DH.04.01.00	
b	1	Hinge	135DH.04.04.00	
c	12	Washer	DIN 125 M16	
d	8	Nut	DIN 985 M16	
e	2	Distance plate above	ST0028.03	See "Rear hatch setup"
f	4	Bolt	DIN 913 M16x80	
g	4	Distance plate below	ST0028.02	See "Rear hatch setup"
h	1	Rear hatch lock right	135DH.04.03.00	
i	8	Washer	DIN 125 M12	
j	8	Bolt	DIN 933 M16x50	Replace M16 bolts with eye bolts for lifting rear hatch
l	1	Rear hatch lock left	135DH.04.03.00	KP

**Table 8.9.** - Components of rear hatch 135DH.04.00.00/ 165DH.04.00.00

## 10.Components of arms



**Figure 8.10.** – Components of lifting arm 135DH.04.00.00/ 165DH.04.00.00

Pos.	QTY.	Part name	Drawing No. 135DH	Drawing No. 165DH/195DH	Description
a	2	Slide bearing	D30 L25	D30 L25	
b	1	Arm body	135DH.04.00.00	165DH.04.00.00	b -left arm body e- right arm body
c	3	Bolt	DIN 7991 M12x25	DIN 7991 M12x25	
d	1	Corner filling left	OT0035	OT0035	d -left corner filling f- right corner filling

**Table 8.10.** - Components of arms 135DH.04.00.00/ 165DH.04.00.00

## 11. Setup of rear hatch

Rear hatch of all DH trailers is adjustable for perfect fit. When rear hatch is removed, follow these instructions when reinstalling it:

1. Remove bolts "5" and replace them with M16 lifting eyes.
2. Lift rear hatch between lifting arms "1". Keep bolts "4" and "7" loose. You need to lift lifting arms to get the hatch on.
3. Place hatch between the arms. Add pin "2" and lock it with bolt "3". There will be a gap of  $5 \pm 2$ mm between top of arm and top of hatch (view "A"). Raise or lower the lifting arm "1" if necessary.

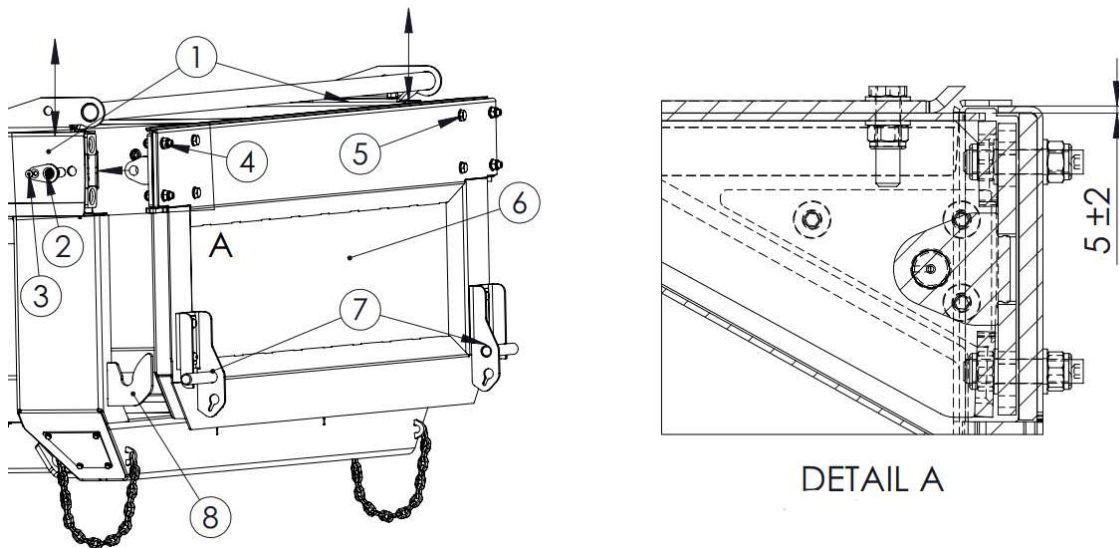


Figure 8.11.3 – Lifting of rear hatch

4. When rear hatch is at its place, there will be 0...1mm gap between sidewalls of box and hatch – this will center the hatch.

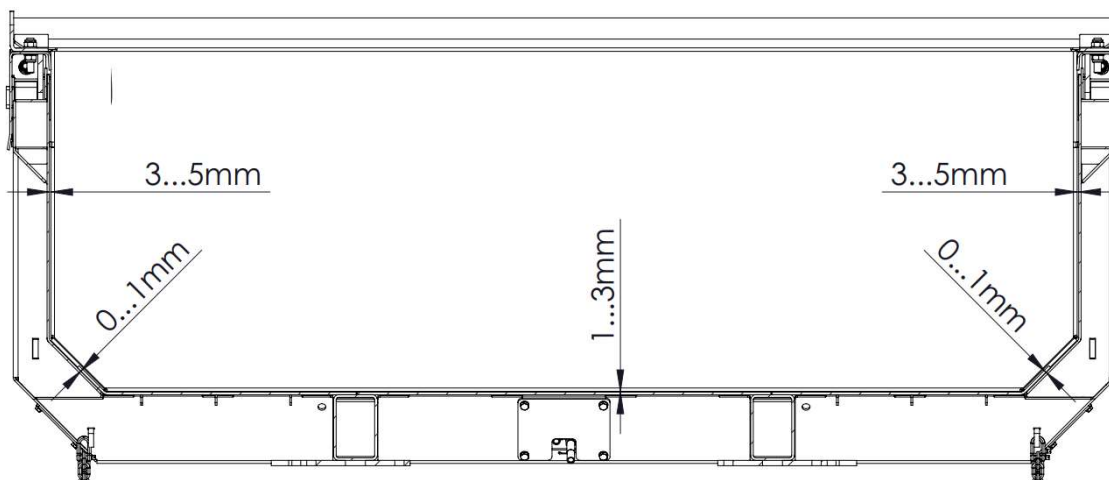
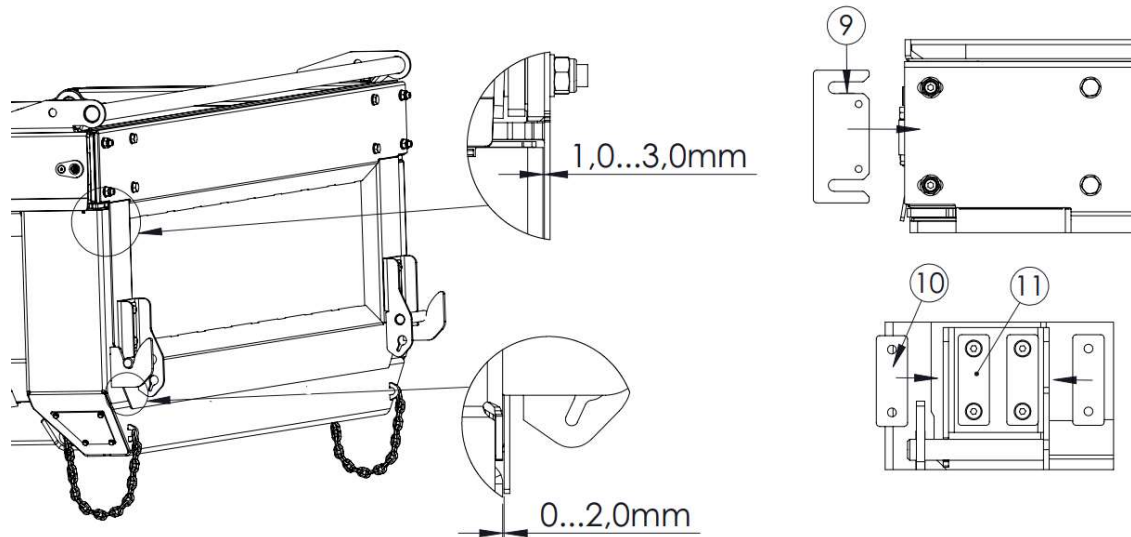


Figure 8.11.4 Internal gaps of rear hatch

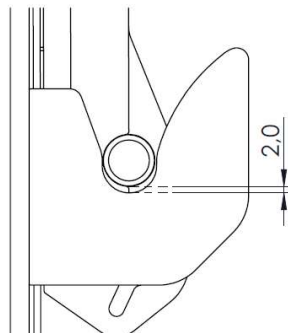
5. Adjust the hatch distance from back end:

- a. Gap at the top should be 1...3mm. Add distance plate "9" to increase and remove to reduce the gap.
- b. Gap at the bottom should be 0...2mm. Add distance plate "10" underneath bottom lock "7" to increase and remove to reduce the gap.



**Figure 8.11.5**– External gaps of rear hatch

6. If all is adjusted raise the bottom lock app. 2mm from the hook



**Figure 8.11.6.** – Bottom lock height of rear hatch

7. Tighten all joints:
  - a. Bolt connection "4" tightening torque – 140Nm
  - b. Bolt connection for lock "7" tightening torque – 70Nm

## 12. Hydraulic system

### 1. 135DH

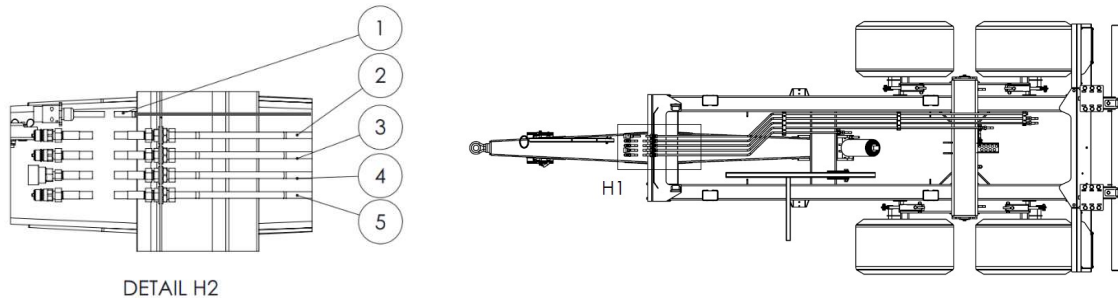


Figure 8.12.1.1. – Hydraulic lines for 135DH

Line no.	Line function
1	Electrics
2	Rear hatch up
3	Rear hatch down
4	Brakes
5	Tilting

Table 8.12.1.1. - Hydraulic lines for 135DH

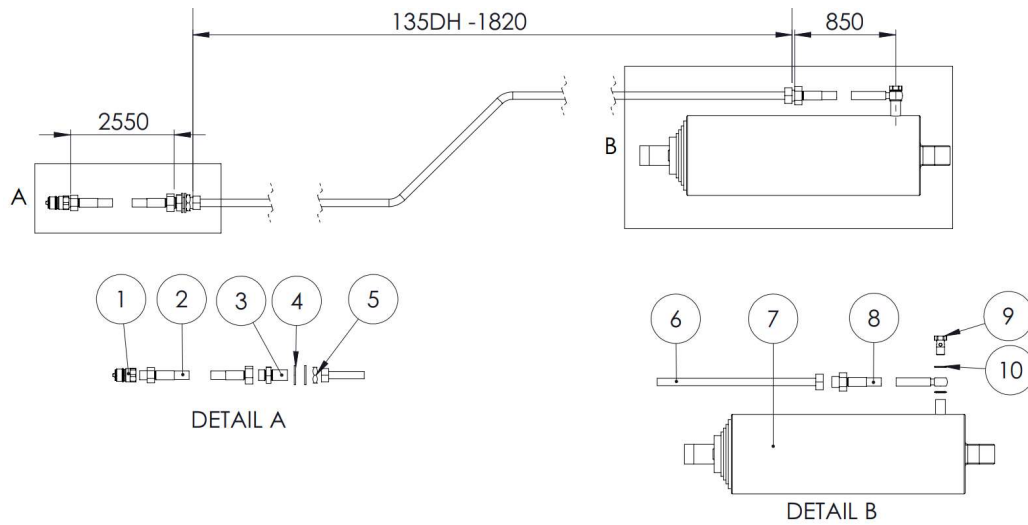


Figure 8.12.1.2. – Tilting line for 135DH

Pos	QTY.	Part name	Standard	Thread size 1	Thread size 2
1	1	Quick coupling		5552 Female 1/2"	
2	1	Hydraulic hose	EN857 2SC 1/2"	Male 1/2"	Female M22x1,5
3	1	Adapter		Male M22x1,5	Male M22x1,5
4	2	Washer	DIN 125	M22	
5	1	Thin nut	DIN 439	M22	
6	1	OT135R01		Female M22	Female M22x1,5
7	1	Tilting cylinder	NAT 6	1/2"	
8	1	Hydraulic hose	EN857 2SC 1/2"	Male M22x1,5	Banjo 1/2"
9	1	Banjo bolt		1/2"	
10	2	Bonded seal washer		1/2"	

Table 8.12.1.2. – Components for tilting line (135DH)



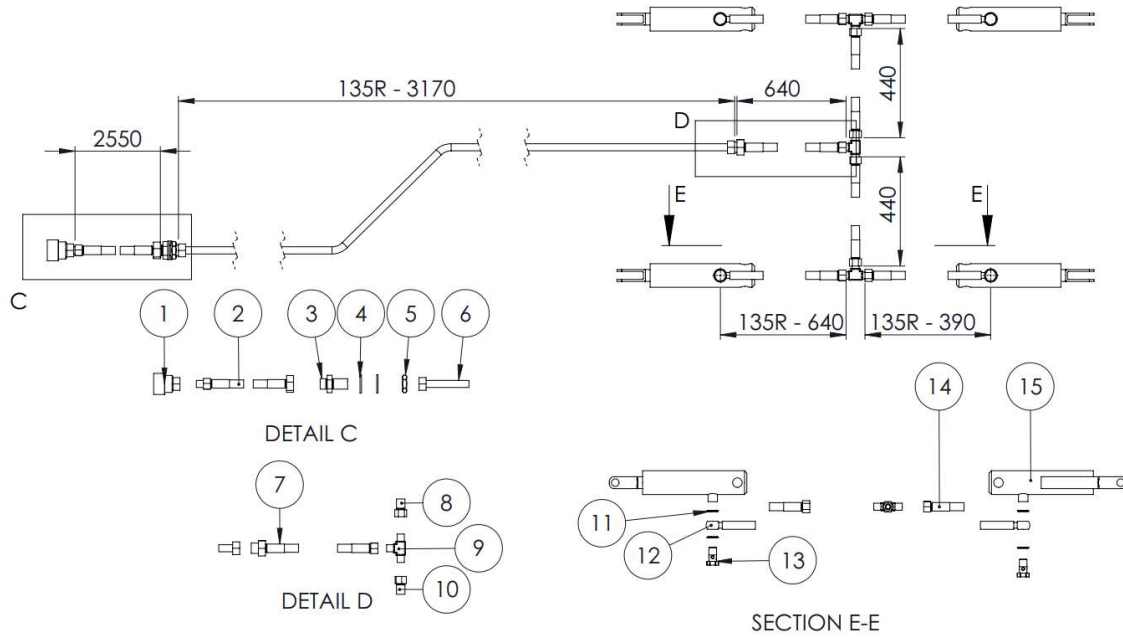
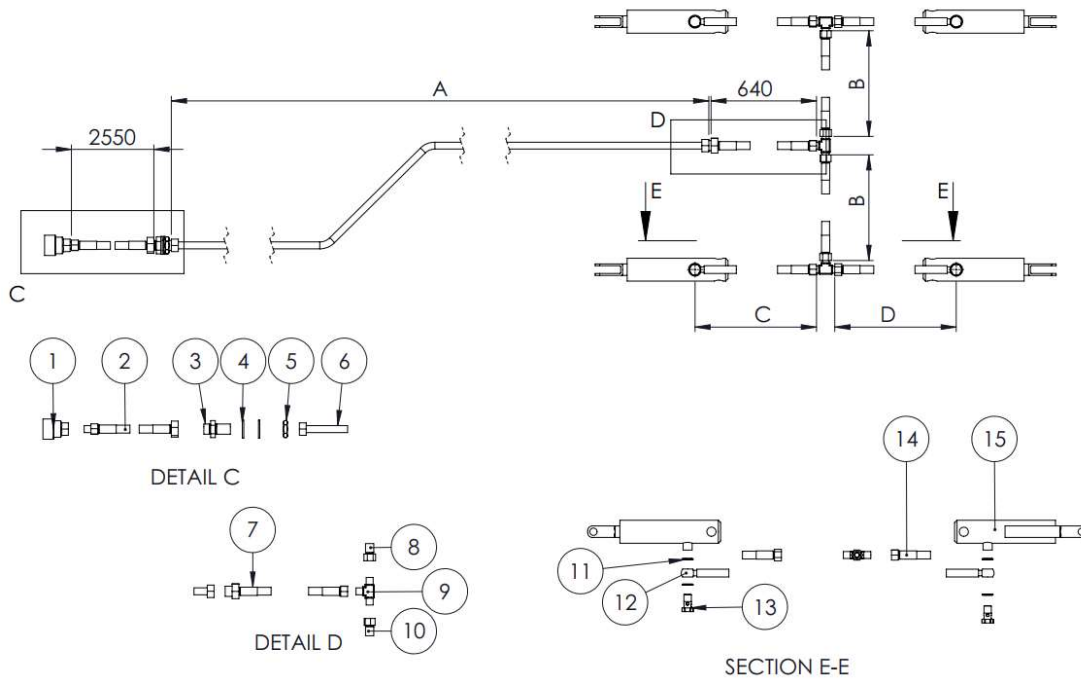


Figure 8.12.1.3. – Hydraulic brake line for 135DH – 4 brakes

Pos	QTY.	Part name	Standard	Thread size 1	Thread size 2	Thread size 3
1	1	Quick coupling	LSQ-S10	Female 3/8"		
2	1	Hydraulic hose	EN857 2SC 3/8"	Male 3/8"	Female M22x1,5	
3	1	Adapter		Male M22x1,5	Male M22x1,5	
4	2	Washer	DIN 125	M22		
5	1	Thin nut	DIN 439	M22		
6	1	OT135R02		Female M22	Female M22x1,5	
7	1	Hydraulic hose	EN857 2SC 3/8"	Male M22x1,5	Female 3/8"	
8	1	Hydraulic hose	EN857 2SC 3/8"	Female 3/8"	Female 3/8"	
9	3	T-adapter		Male 3/8"	Male 3/8"	Male 3/8"
10	1	Hydraulic hose	EN857 2SC 3/8"	Female 3/8"	Female 3/8"	
11	8	Bonded seal washer		1/2"		
12	2	Hydraulic hose	EN857 2SC 3/8"	Female 3/8"	Banjo 3/8"	
13	4	Banjo bolt		3/8"		
14	2	Hydraulic hose	EN857 2SC 3/8"	Female 3/8"	Banjo 3/8"	
15	4	Brake cylinder	40/25-100	Female 3/8"		

Table 8.12.1.3. – Components for hydraulic brake line - 4 brakes (135DH)



Standard Hydraulic brake line for – 4H brakes

Pos	QTY.	Part name	Standard	Thread size 1	Thread size 2	Thread size 3
1	1	Quick coupling	LSQ-S10	Female 3/8"		
2	1	Hydraulic hose	EN857 2SC 3/8"	Male 3/8"	Female M22x1,5	
3	1	Adapter		Male M22x1,5	Male M22x1,5	
4	2	Washer	DIN 125	M22		
5	1	Thin nut	DIN 439	M22		
6	1	HT15-		Female M22	Female M22x1,5	
7	1	Hydraulic hose	EN857 2SC 3/8"	Male M22x1,5	Female 3/8"	
8	1	Hydraulic hose	EN857 2SC 3/8"	Female 3/8"	Banjo 3/8"	
9	1	T-adapter		Male 3/8"	Male 3/8"	Male 3/8"
10	1	Hydraulic hose	EN857 2SC 3/8"	Female 3/8"	Banjo 3/8"	
11	2	Brake cylinder	40/25-100	Female 3/8"		
12	4	Bonded seal washer		1/2"		
13	2	Banjo bolt		3/8"		

Components for hydraulic brake line - 4 brakes

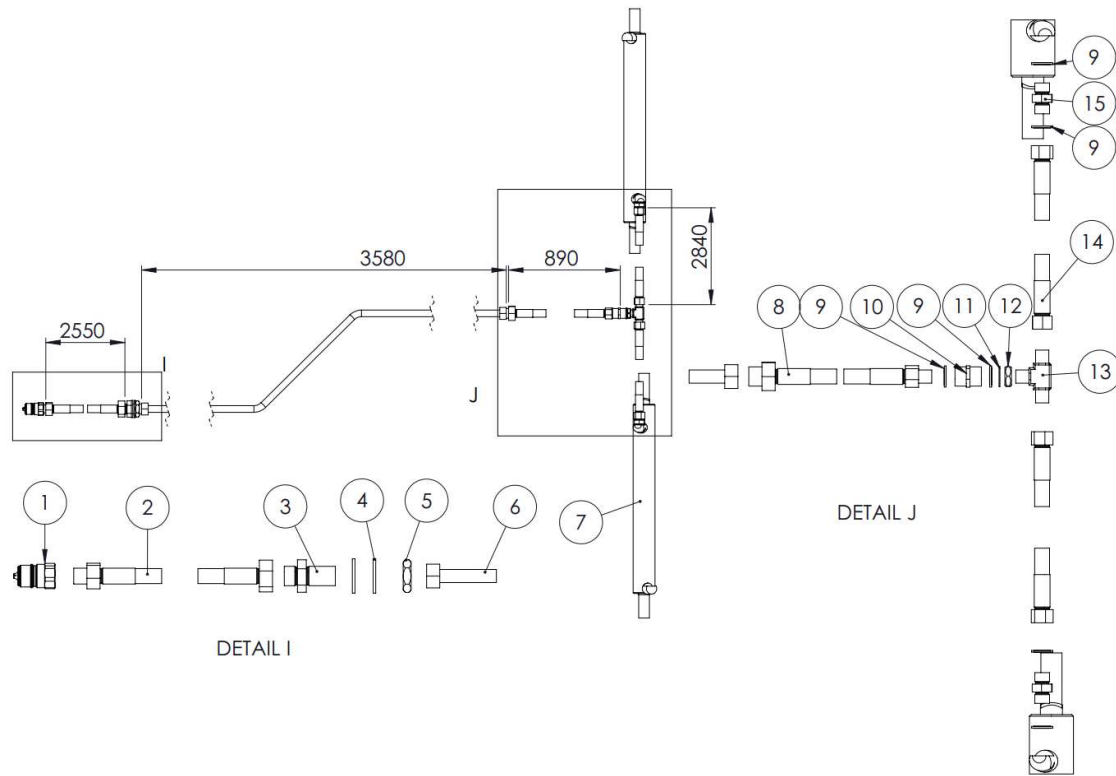


Figure 8.12.1.5. – Rear hatch down line – 135DH

Pos	QTY.	Part name	Standard	Thread size 1	Thread size 2	Thread size 3
1	1	Quick coupling	5552	Female 1/2"		
2	1	Hydraulic hose	EN857 2SC 3/8"	Male 1/2"	Female M22x1,5	
3	1	Adapter		Male M22x1,5	Male M22x1,5	
4	2	Washer	DIN 125	M22		
5	1	Thin nut	DIN 439	M22		
6	1	OT135R03		Female M22x1,5	Female M22x1,5	
7	2	Hydraulic cylinder	HC-40-25-313_DH	Female 3/8"	Female 3/8"	
8	1	Hydraulic hose	EN857 2SC 3/8"	Male M22x1,5	Male 3/8"	
9	6	Bonded seal washer		3/8"		
10	1	Adapter		Female 3/8"	Female 3/8"	
11	1	Thin washer		3/8"		
12	1	Thin nut	DIN 439	3/8"		
13	1	T-adapter		Male 3/8"	Male 3/8"	Male 3/8"
14	2	Hydraulic hose	EN857 2SC 3/8"	Female 3/8"	Male 3/8"	
15	2	Adapter		Female 3/8"	Female 3/8"	

Table 8.12.1.5. – Components for Rear hatch down line – 135DH

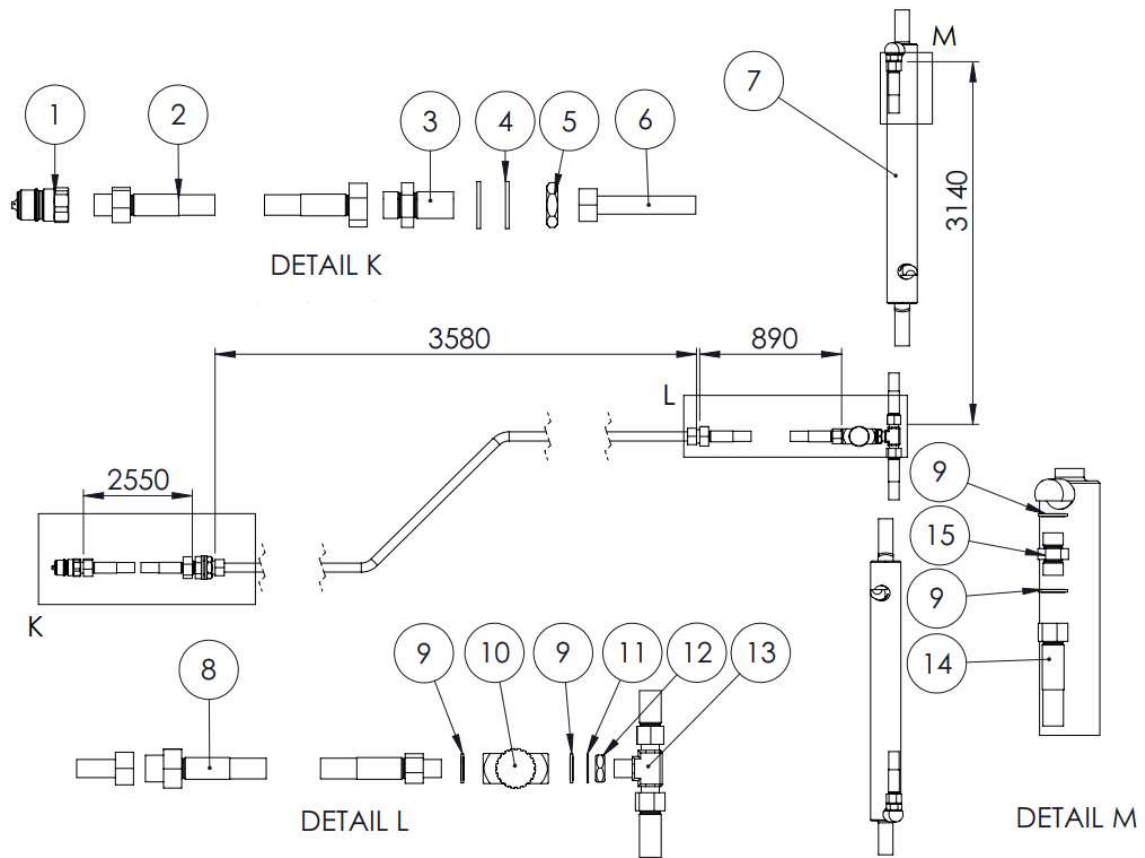
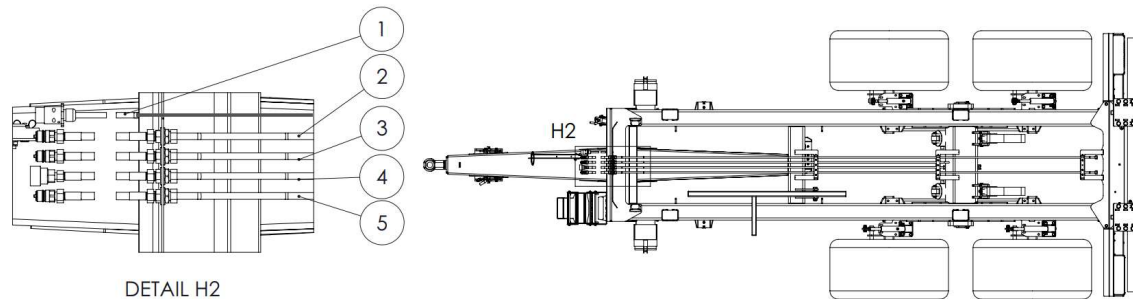


Figure 8.12.1.6. – Rear hatch up line – 135DH

Pos	QTY.	Part name	Standard	Thread size 1	Thread size 2	Thread size 3
1	1	Quick coupling	5552	Female 1/2"		
2	1	Hydraulic hose	EN857 2SC 3/8"	Male 1/2"	Female M22x1,5	
3	1	Adapter		Male M22x1,5	Male M22x1,5	
4	2	Washer	DIN 125	M22		
5	1	Thin nut	DIN 439	M22		
6	1	OT135R03		Female M22x1,5	Female M22x1,5	
7	2	Hydraulic cylinder	HC-40-25-313_DH	Female 3/8"	Female 3/8"	
8	1	Hydraulic hose	EN857 2SC 3/8"	Male M22x1,5	Male 3/8"	
9	6	Bonded seal washer		3/8"		
10	1	2 way reducer		Female 3/8"	Female 3/8"	
11	1	Thin washer		3/8"		
12	1	Thin nut	DIN 439	3/8"		
13	1	T-adaptor		Male 3/8"	Male 3/8"	Male 3/8"
14	2	Hydraulic hose	EN857 2SC 3/8"	Female 3/8"	Male 3/8"	
15	2	Adapter		Female 3/8"	Female 3/8"	

Table 8.12.1.6. – Components for Rear hatch up line – 135DH

## 2. 165DH/195DH



**Figure 8.12.2.1.** – Hydraulic lines for 165DH/195DH

Line no.	Line function
1	Electrics
2	Rear hatch up
3	Tilting
4	Brakes
5	Rear hatch down

**Table 8.12.2.1.** - Hydraulic lines for 165DH/195DH

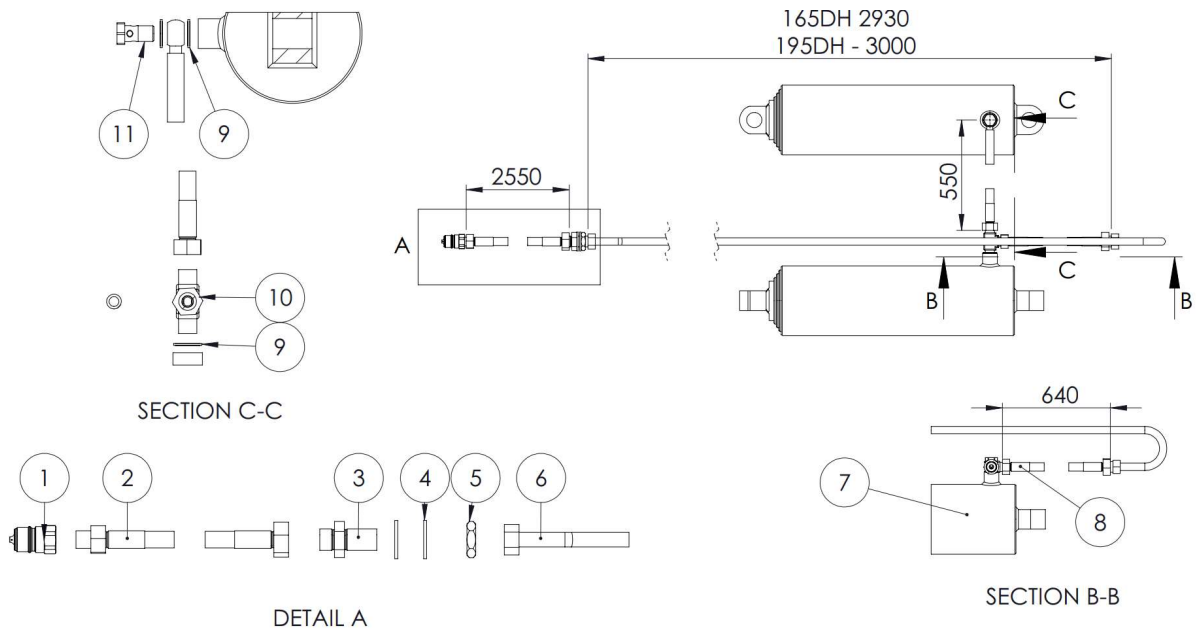
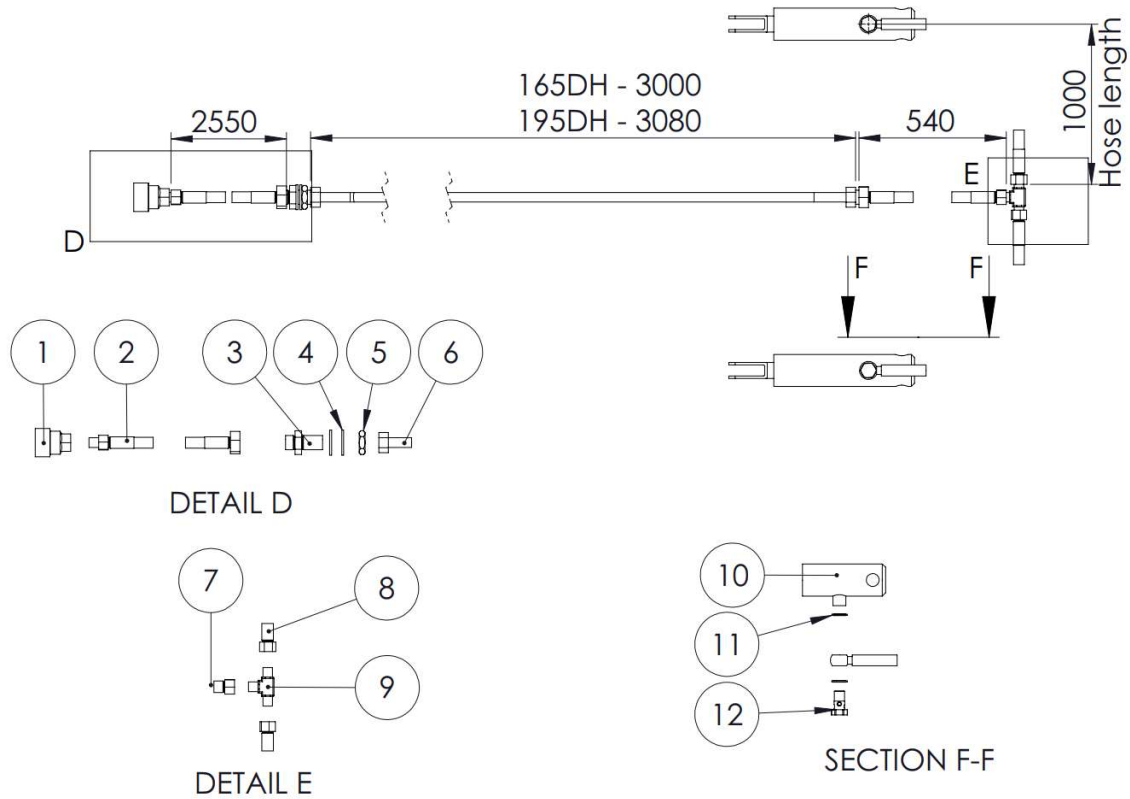


Figure 8.12.2.2. – Tilting line for 165DH/195DH

Pos	QTY.	Part name 165DH	Part name 195DH	Standard	Thread size 1	Thread size 2	Thread size 3
1	1	Quick coupling	Quick coupling	5552	Female 1/2"		
2	1	Hydraulic hose	Hydraulic hose	EN857 2SC 1/2"	Male 1/2"	Female M22x1,5	
3	1	Adapter	Adapter		Male M22x1,5	Male M22x1,5	
4	2	Washer	Washer	DIN 125	M22		
5	1	Thin nut	Thin nut	DIN 439	M22		
6	1	OT165R01	OT195R01		Female M22x1,5	Female M22x1,5	
7	2	Tilting cylinder NAS 5	Tilting cylinder NAT 6		1/2"		
8	1	Hydraulic hose	Hydraulic hose	EN857 2SC 1/2"	Male M22x1,5	Female 1/2"	
9	3	Bonded seal washer	Bonded seal washer		1/2"		
10	1	T-adapter	T-adapter		Male 1/2"	Male 1/2"	Male 1/2"
11	2	Bonded seal washer	Bonded seal washer		1/2"		

Table 8.12.2.2. – Components for tilting line (165DH/195DH)



**Figure 8.12.2.3.**– Hydraulic brake line for 165DH/195DH – 2 brakes

Pos	QTY.	Part name 165DH	Part name 195DH	Standard	Thread size 1	Thread size 2	Thread size 3
1	1	Quick coupling	Quick coupling	LSQ-S10	Female 3/8"		
2	1	Hydraulic hose	Hydraulic hose	EN857 2SC 3/8"	Male 3/8"	Female M22x1,5	
3	1	Adapter	Adapter		Male M22x1,5	Male M22x1,5	
4	2	Washer	Washer	DIN 125	M22		
5	1	Thin nut	Thin nut	DIN 439	M22		
6	1	OT165R02	OT195R02		Female M22x1,5	Female M22x1,5	
7	1	Hydraulic hose	Hydraulic hose	EN857 2SC 3/8"	Male M22x1,5	Female 3/8"	
8	2	Hydraulic hose	Hydraulic hose	EN857 2SC 3/8"	Female 3/8"	Banjo 3/8"	
9	1	T-adapter	T-adapter		Male 3/8"	Male 3/8"	Male 3/8"
10	2	Brake cylinder	Brake cylinder	40/25-100	Female 3/8"		
11	4	Bonded seal washer	Bonded seal washer		1/2"		
12	2	Banjo bolt	Banjo bolt		3/8"		

**Table 8.12.2.3.** – Components for hydraulic brake line - 2 brakes (165DH/195DH)

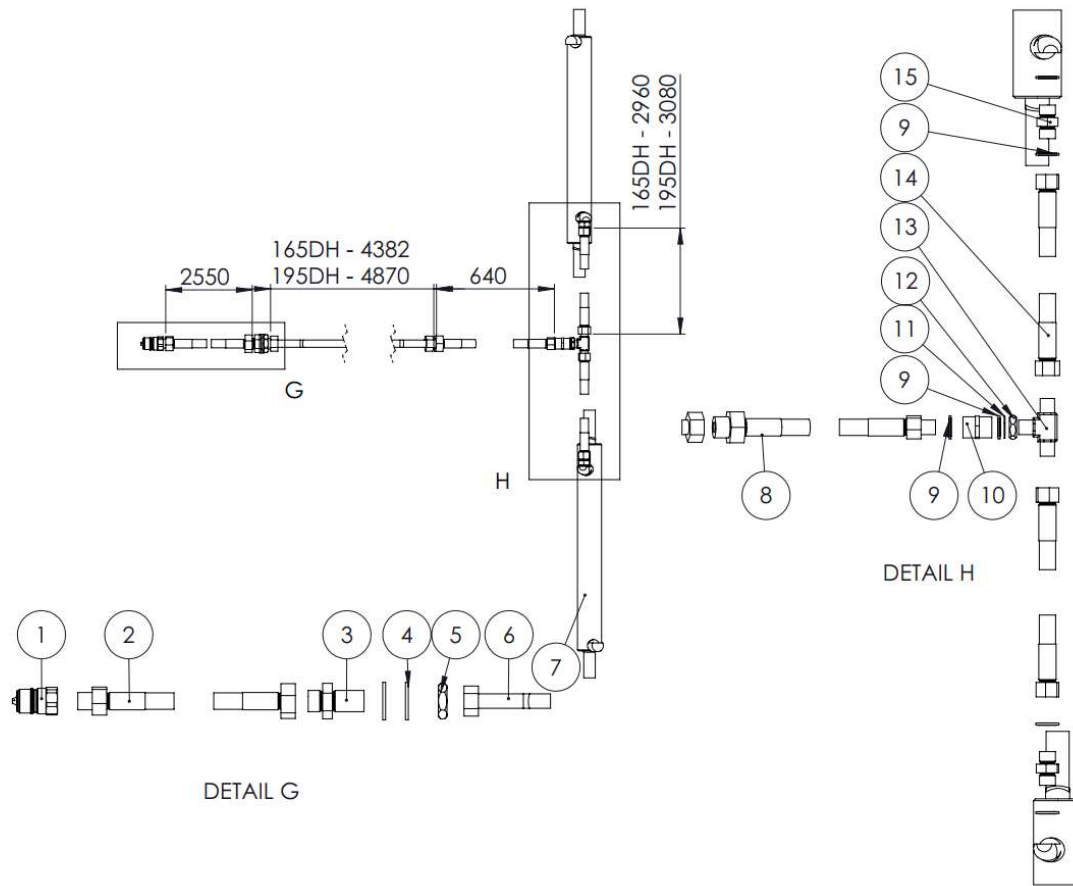


Figure 8.12.2.4. – Rear hatch down line – 165DH/195DH

Pos	QTY.	Part name 165DH	Part name 195DH	Standard	Thread size 1	Thread size 2	Thread size 3
1	1	Quick coupling	Quick coupling	5552	Female 1/2"		
2	1	Hydraulic hose	Hydraulic hose	EN857 2SC 3/8"	Male 1/2"	Female M22x1,5	
3	1	Adapter	Adapter		Male M22x1,5	Male M22x1,5	
4	2	Washer	Washer	DIN 125	M22		
5	1	Thin nut	Thin nut	DIN 439	M22		
6	1	OT165R03	OT195R03		Female M22x1,5	Female M22x1,5	
7	2	Hydraulic cylinder	Hydraulic cylinder	40/25-313_DH	Female 3/8"	Female 3/8"	
8	1	Hydraulic hose	Hydraulic hose	EN857 2SC 3/8"	Male M22x1,5	Male 3/8"	
9	6	Bonded seal washer	Bonded seal washer		3/8"		
10	1	Adapter	Adapter		Female 3/8"	Female 3/8"	
11	1	Thin washer	Thin washer		3/8"		
12	1	Thin nut	Thin nut	DIN 439	3/8"		
13	1	T-adapter	T-adapter		Male 3/8"	Male 3/8"	Male 3/8"
14	2	Hydraulic hose	Hydraulic hose	EN857 2SC 3/8"	Female 3/8"	Female 3/8"	
15	2	Adapter	Adapter		Male 3/8"	Male 3/8"	

Table 8.12.2.4. – Rear hatch down line – 165DH/195DH



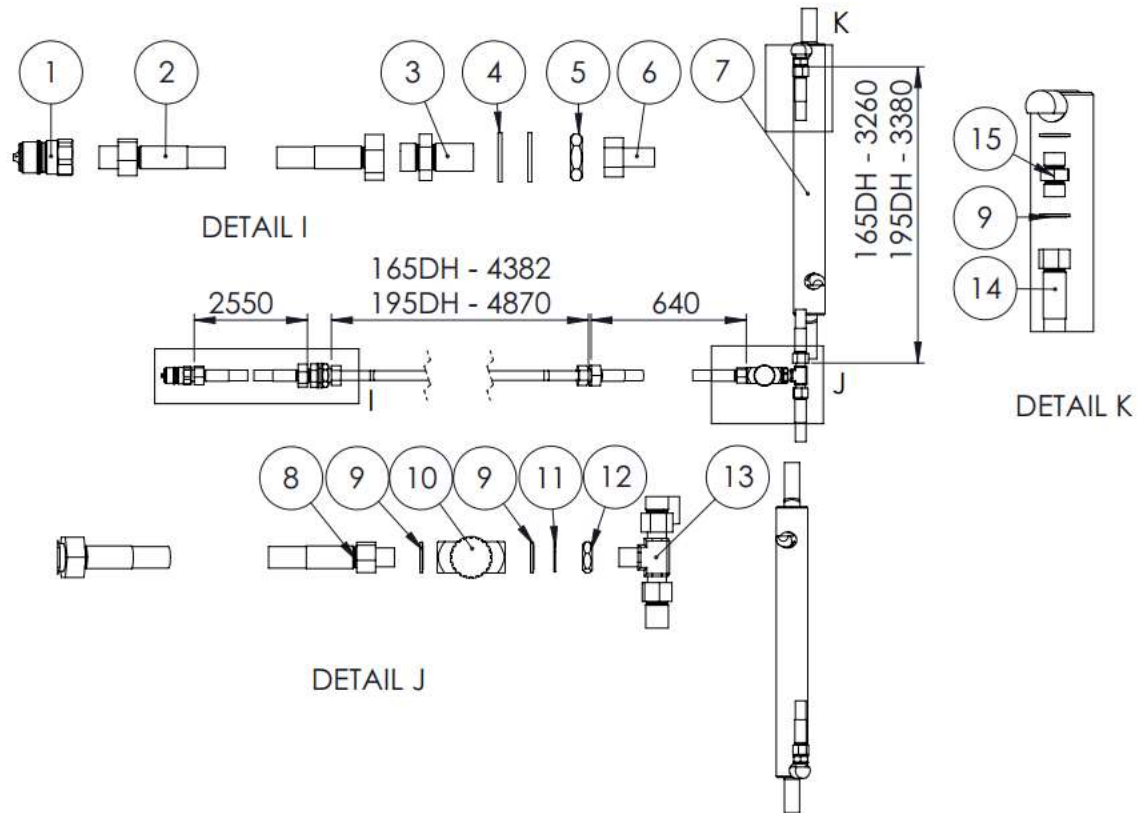


Figure 8.12.2.5. – Rear hatch up line – 165DH/195DH

Pos	QTY.	Part name	Standard	Thread size 1	Thread size 2	Thread size 3
1	1	Quick coupling	5552	Female 1/2"		
2	1	Hydraulic hose	EN857 2SC 3/8"	Male 1/2"	Female M22x1,5	
3	1	Adapter		Male M22x1,5	Male M22x1,5	
4	2	Washer	DIN 125	M22		
5	1	Thin nut	DIN 439	M22		
6	1	OT165R03		Female M22x1,5	Female M22x1,5	
7	2	Hydraulic cylinder	40/25-313_DH	Female 3/8"	Female 3/8"	
8	1	Hydraulic hose	EN857 2SC 3/8"	Male M22x1,5	Male 3/8"	
9	6	Bonded seal washer		3/8"		
10	1	2 way reducer		Female 3/8"	Female 3/8"	
11	1	Thin washer		3/8"		
12	1	Thin nut	DIN 439	3/8"		
13	1	T-adapter		Male 3/8"	Male 3/8"	Male 3/8"
14	2	Hydraulic hose	EN857 2SC 3/8"	Female 3/8"	Female 3/8"	
19	2	Adapter		Male 3/8"	Male 3/8"	

Table 8.12.2.5. – Rear hatch up line – 165DH/195DH

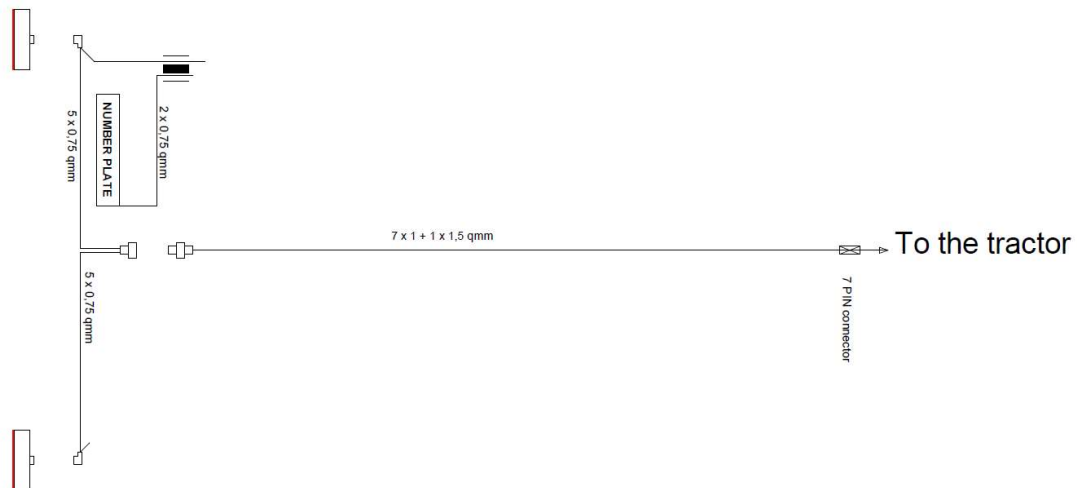
3. Hydraulic cylinder repairs



Cylinder type	Application	Trailer type	Repair method
NAS 5	Tilting cylinder	165DH	Cannot be repaired – replace for original part
NAT 6	Tilting cylinder	135DH/ 195DH	Cannot be repaired – replace for original part
40/25-313	Tailgate lifting cylinder	135DH/ 165DH/ 195DH	Cannot be repaired – replace for original part
40/25-100	Brake cylinder	135DH/ 165DH/ 195DH	Cannot be repaired – replace for original part

**Table 8.12.3.** – Hydraulic cylinder table

13. Electrics

1. Electrical scheme for 135DH and 165DH:



	DH80042002 or DH80101002
	DC connector

**Figure 8.13.1.** –Electrical scheme

2. 7 pin connector scheme

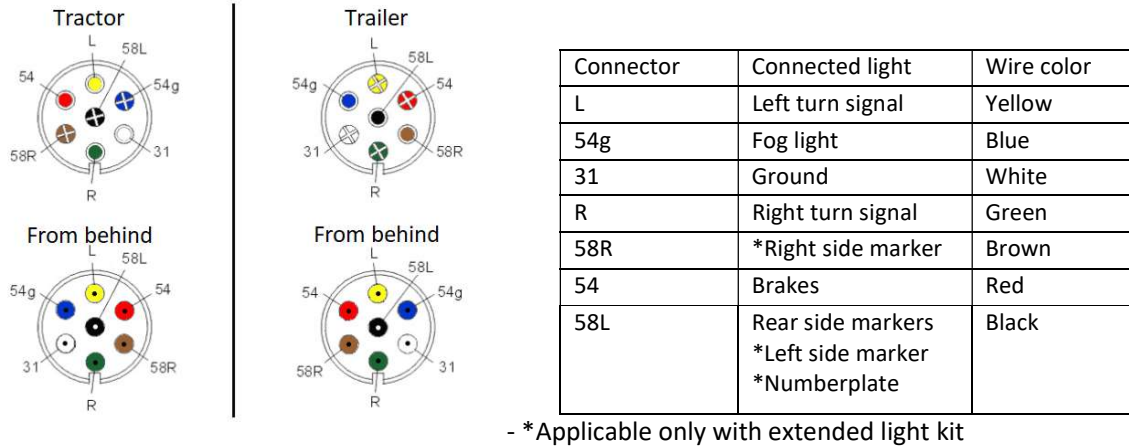


Figure 8.13.2. –7 pin connector

3. Connection of lights

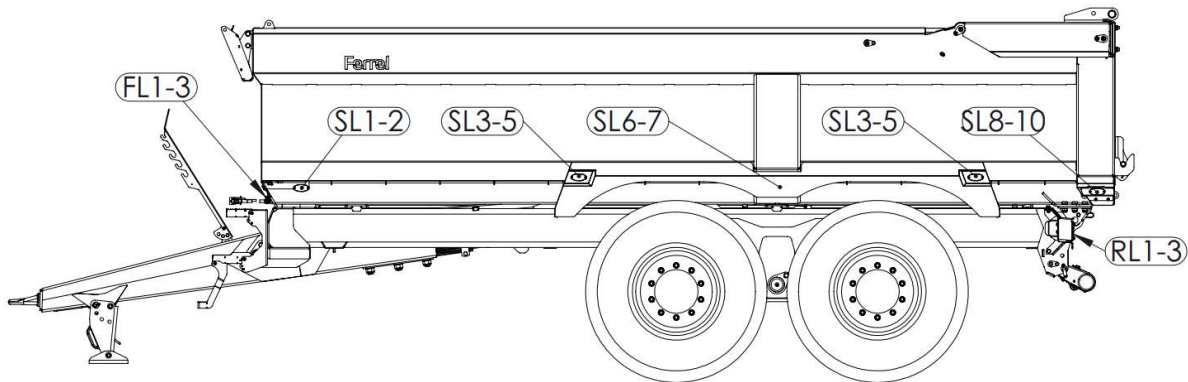
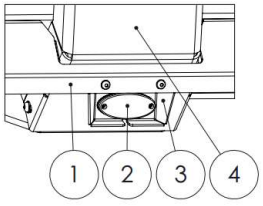
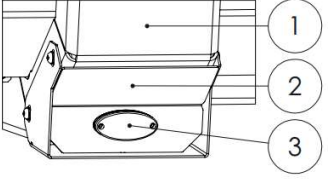
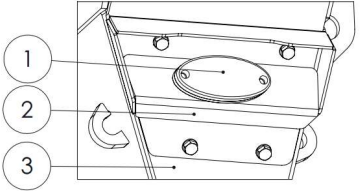
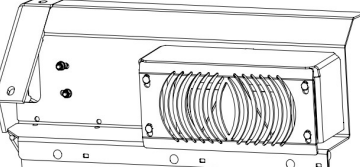


Figure 8.13.3. Light positions

Light pos.	Type	Applicable configuration	Applicable model	Assembling	Description
FL1-2	White front light	G6; G7	135DH 165DH 195DH		1. Front light FL1-2 (2pcs) 2. Trailer box 3. Flange ST0015.04 (2pcs) 4. Side light OT0026.002 (2pcs)
SL1-2	Orange side lamp	G6;G7	135DH 165DH 195DH		
SL3-5	Orange side lamp	G6;G7 With MG1	165DH 195DH		

SL6-7	Orange side lamp	G6;G7 With MG1	135DH		<ol style="list-style-type: none"> <li>1. Mudguard 135DH.05.08.00 (2pcs)</li> <li>2. Side light OT0026.002 (2pcs)</li> <li>3. Flange 135DH.05.08.07 (2pcs)</li> <li>4. Trailer box</li> </ol>
SL6-7	Orange side lamp	G6;G7 Without MG1	135DH 165DH 195DH		<ol style="list-style-type: none"> <li>1. Trailer box</li> <li>2. Light flange (2pcs): <ul style="list-style-type: none"> <li>• 135DH - 135DH.05.03.00</li> <li>• 165DH - 165DH.05.03.00</li> <li>• 195DH - 165DH.05.03.00</li> </ul> </li> <li>3. Side light OT0026.002</li> </ol>
SL8-10	Orange side lamp	G6;G7	135DH 165DH 195DH		<ol style="list-style-type: none"> <li>1. Side light OT0026.002 (2pcs)</li> <li>2. Flange ST0015.06.00 (2pcs)</li> <li>3. Trailer box</li> </ol>
RL1-3	Rear light set	Base model	135DH 165DH 195DH		See section "Spare parts of rear light frame"

**Table 8.13.3.** Light positions

#### 4. Repairs

All electrical repairs should be done by specialist.

All lights used on Ferrel trailers are LED-s. They cannot be opened for repairs. In case of damaged light replace for original part.

#### 14. Handbrake

On Ferrel DH trailers handbrake is an accessory. It can be retrofitted on right side of the trailer since 2020.08.

Use handbrake when parking trailer on a slope or when maintaining the trailer.

Make sure the handbrake is firmly on when parking – Turn the crank clockwise until brake cylinder is at the front end of the slot (pic. 1)

Make sure the handbrake is completely off before driving – Turn the crank counterclockwise until brake cable is loose.

1. Scheme of handbrake 135R

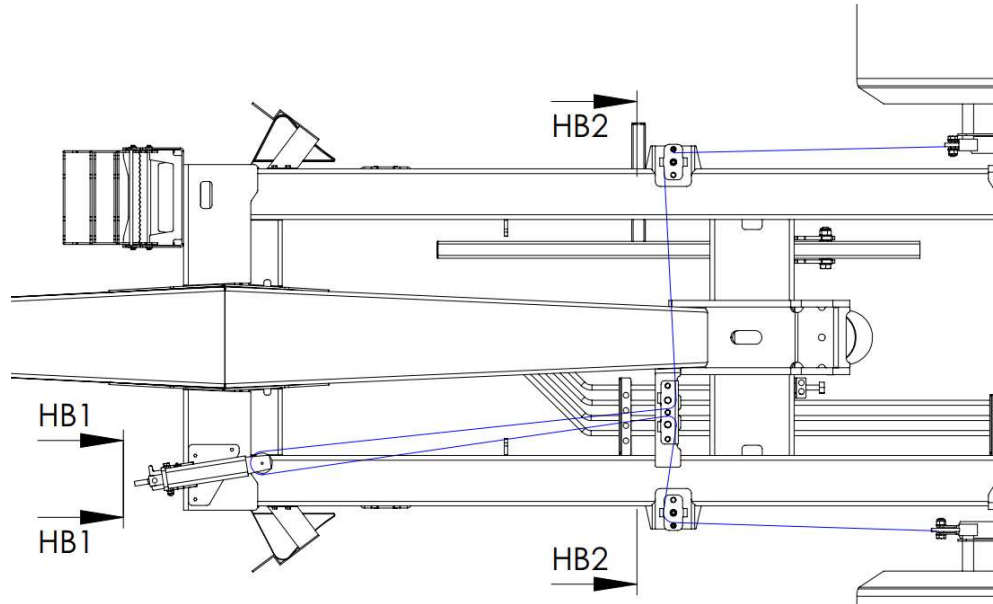


Figure 8.14.1 135DH handbrake cable scheme

2. Scheme of handbrake 165R/195R

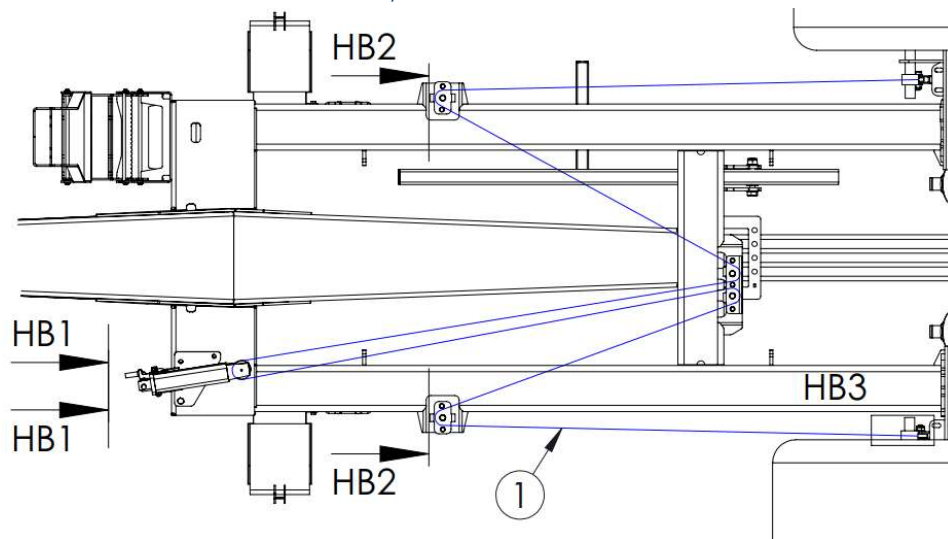


Figure 8.14.2 165R/195R handbrake cable scheme

3. Components of handbrake

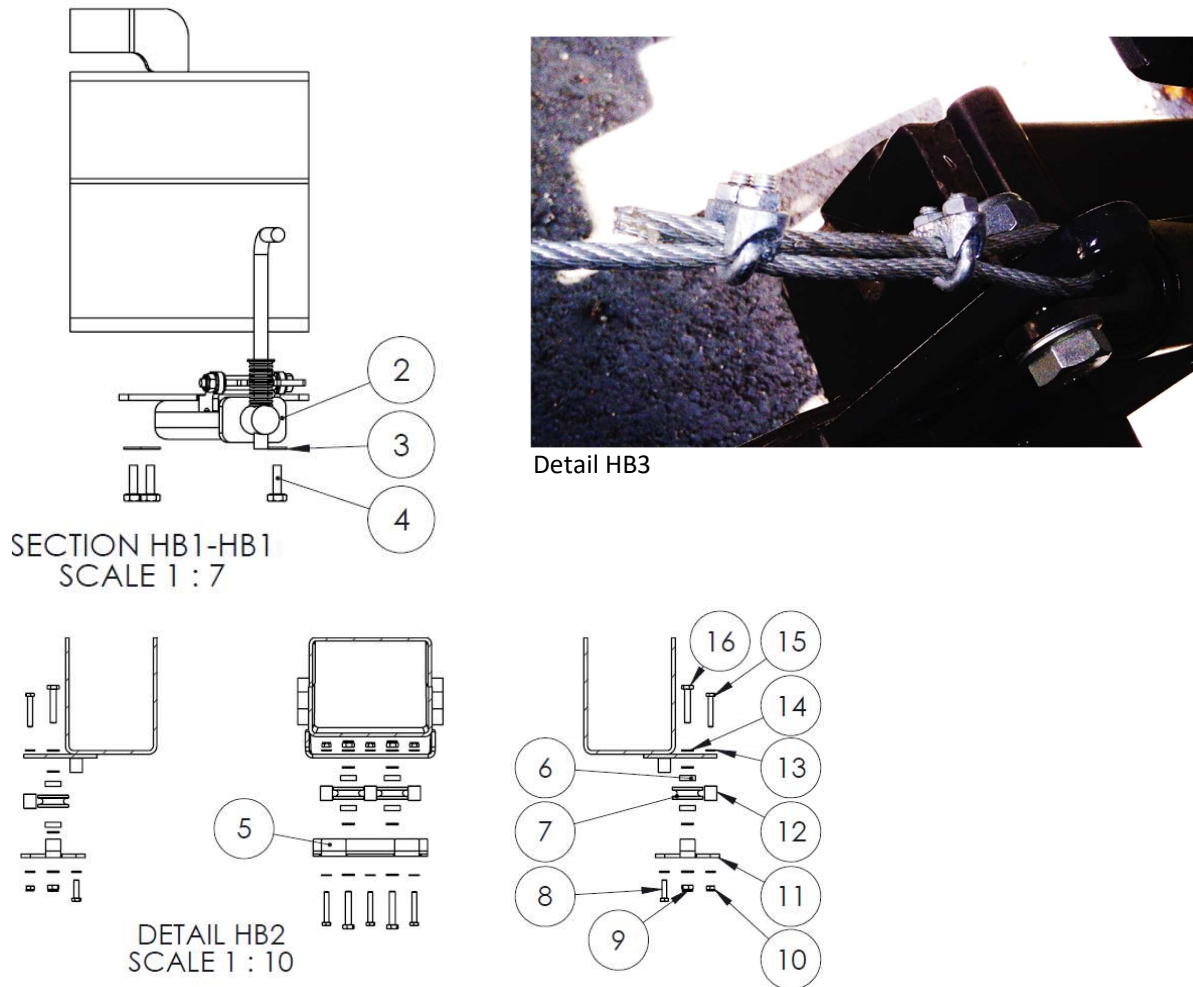


Figure 8.14.3. –Scheme of handbrake

Pos.	QTY	Part name	Part No	Description
1	5,5m	Brake cable	-	D5mm
2	1	Brake crank ass.	FE00.06.01.00	Left hand or right hand
3	3	Washer	DIN 125	M10
4	3	Bolt	DIN 933	M10x30
5	1	Handbrake cover 2	FE00.06.01.04	
6	8	Roller bearing	6000-2RSH	D26_d10
7	4	Cable wheel	FE00.06.01.04	
8	2	Bolt	DIN 933	M8x30
9	4	Nut	DIN 985	M10
10	5	Nut	DIN 985	M8
11	2	Handbrake cover 1	FE00.06.01.03	
12	5	Bushing	FE00.06.01.05	
13	12	Washer	DIN 125	M8
14	16	Washer	DIN 125	M10
15	5	Bolt	DIN 933	M8x50
16	4	Bolt	DIN 933	M10x55

Table 8.14.3. – Components of handbrake

## 9. EXTENSION

### 1. INTRODUCTION

This manual provides a comprehensive overview of the FERREL DH trailer extension. Read this manual carefully before using the extension. Compliance with these requirements guarantees the safe and durable use of the product.

The FERREL trailer extensions are intended only for transporting light weight but high-volume goods. DH trailer extensions are compatible only with specific Ferrel DH trailer.

### 2. TECHNICAL SPECIFICATIONS

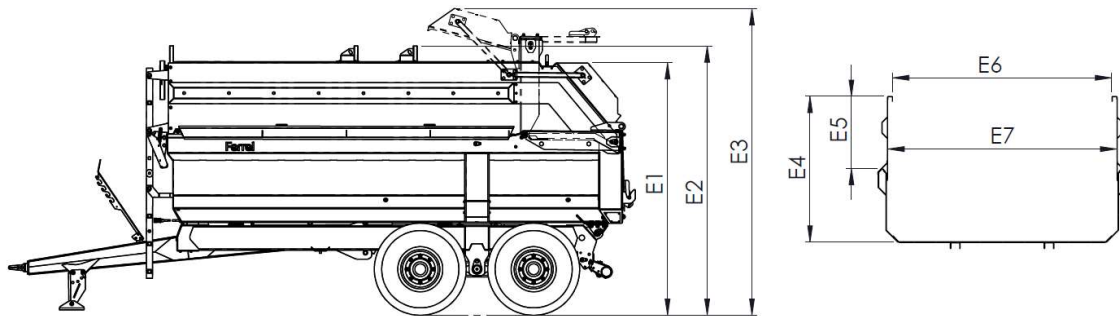


Figure 9.2.1. – Trailer dimensions with extension

Dumpers	External dimensions			Internal dimensions				Total volume
	E1	E2	E3	E4	E5	E6	E7	
<b>135DH</b>	2555	2725	3100	1475	730	2220	2320	15,3m <sup>3</sup>
<b>165DH</b>	2850	3010	3345	1600	730	2220	2320	18,5m <sup>3</sup>
<b>195DH</b>	3040	3190	3535	1710	730	2220	2320	21,6 m <sup>3</sup>

Table 9.2.1. Trailer dimensions with extension

### 3. SAFETY

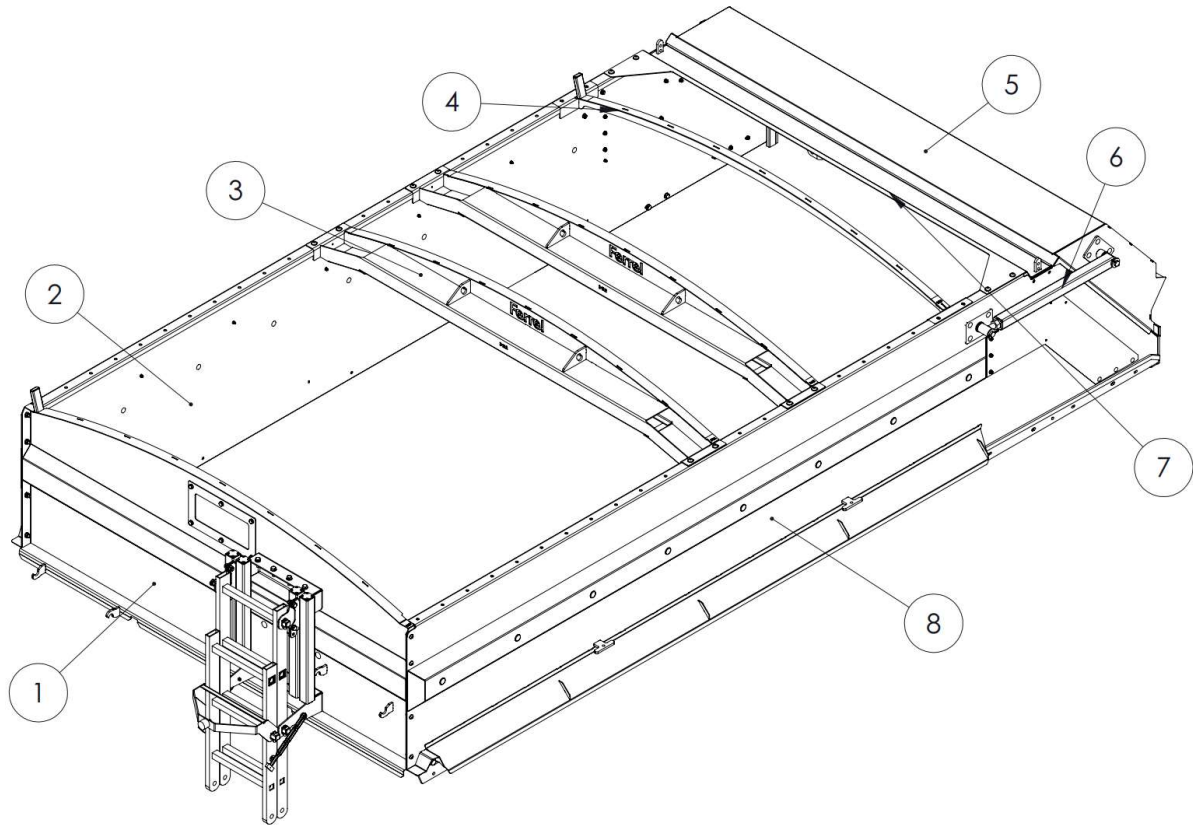
- Ensure lifting the extension is performed on level ground.
- Ensure all fasteners are tight enough to carry the load during the lift.
- The trailer must be immobilized with parking brake, shocks or attached tractor.
- With an extension mounted, the trailer is more influenced by the side wind.
- If extension unit is placed on the ground on stands, ensure it is stable and on even ground.

### 4. MAINTENANCE

- Ferrel DH trailer extensions are maintenance free. No lubrication is required.
- To prolong the extension lifetime, keep it off the ground when not in use.

## 5. SECTIONS AND DETAILS

### 1. Main components of extension

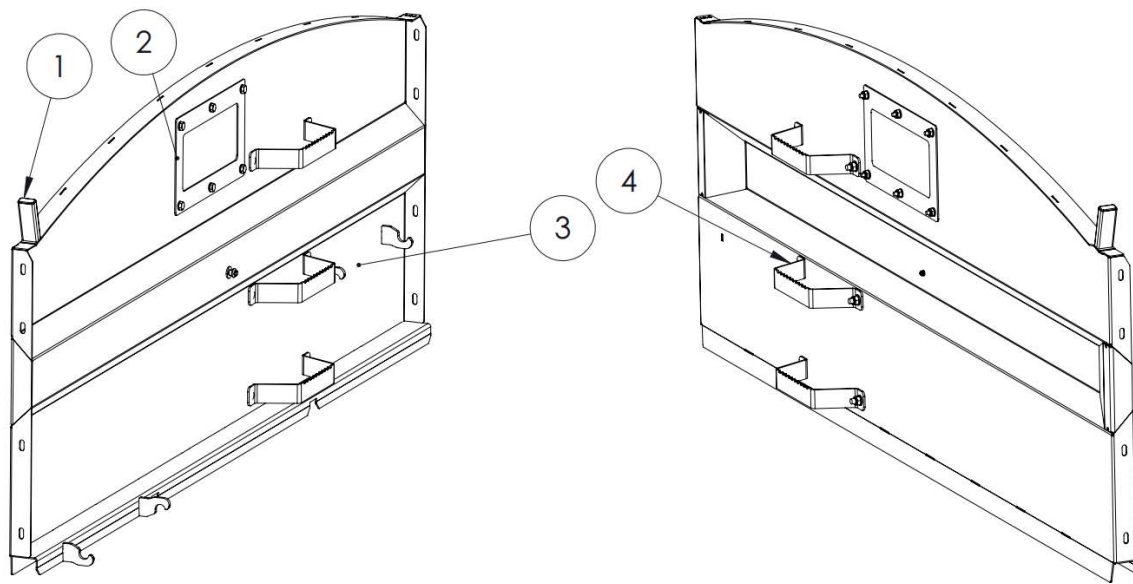


**Figure 9.5.1.1. - Main assembly**

NO.	QTY	Part name	Part number 135DH	Part number 165DH	Part number 195DH	Versions
1	1	Front panel	135DH.15.01.00	135DH.15.01.00	135DH.15.01.00	Base
2	1	Right panel	135DH.15.03.00	165DH.15.03.00	195DH.15.03.00	Base
3	2	Lifting beam	135DH.15.06.00	135DH.15.06.00	135DH.15.06.00	Base
4	1	Sheeting support arc	135DH.15.13.00	135DH.15.13.00	135DH.15.13.00	Accessory
5	1	Rear hatch	135DH.15.04.00	135DH.15.04.00	135DH.15.04.00	Base
6	2	Lifting arm	135DH.15.05.00	135DH.15.05.00	135DH.15.05.00	Base
7	1	Rear groove	135DH.15.08.00	135DH.15.08.00	135DH.15.08.00	Base
8	1	Left panel	135DH.15.02.00	165DH.15.02.00	195DH.15.02.00	Base
9	1	Ladder with supports	FE00.15.05.00	FE00.15.05.00	FE00.15.05.00	Accessory

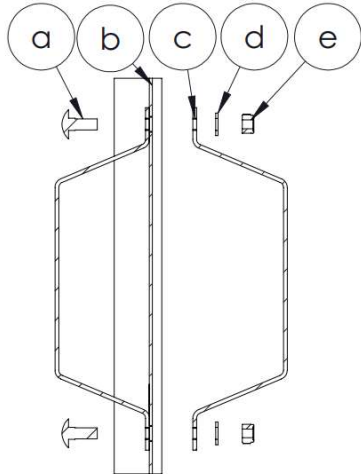
**Table 9.5.1.1. - Components of main assembly**



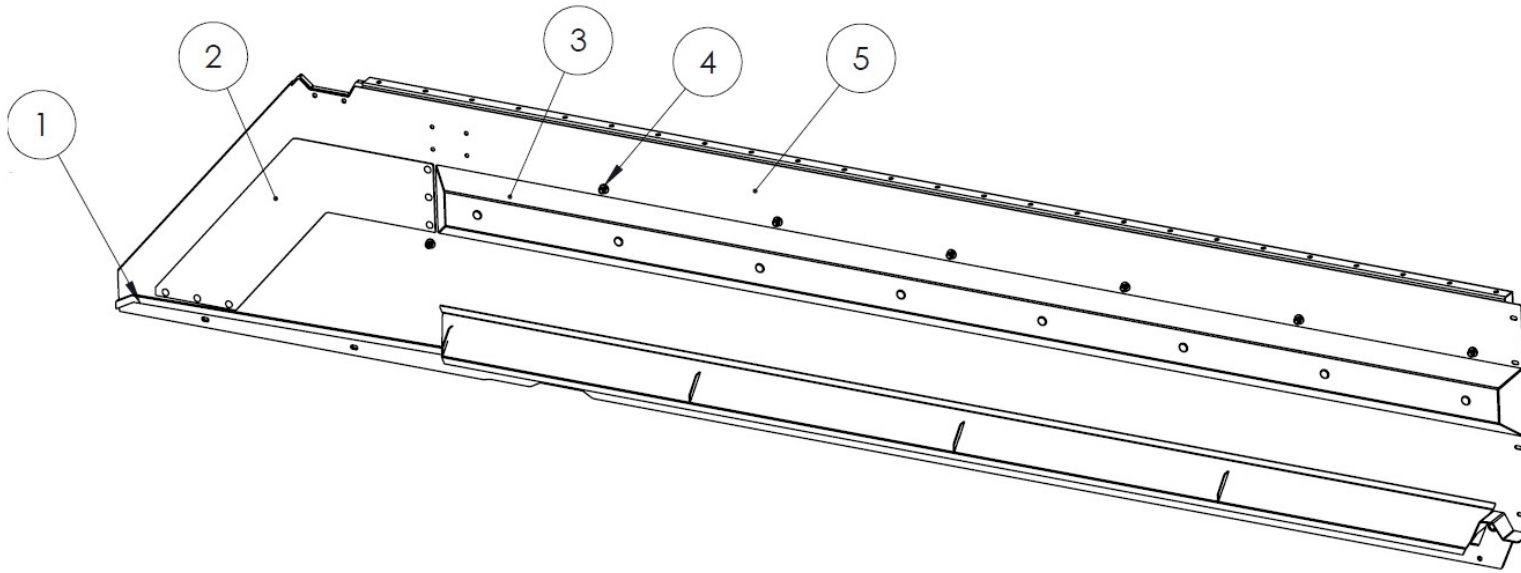


**Figure 9.5.1.2. – components of front panel 135DH.15.01.00**

Pos.	QTY	Part name	Part No	Assembly drawing	Components
1	1	Plastic cap	OT0019.02		40x20
2	1	135DH.15.01.00	Front panel		
3	5	Plastic knob			d. Nut DIN 985 M6 (1psc) e. Washer DIN 125 M6 (1psc) f. 135DH.15.01.00 (1psc) g. Plastic knob (1psc) h. Bolt DIN 933 M6x30 (1psc)

4	1	Step	ST0027.01		<ul style="list-style-type: none"> <li>a. Bolt DIN 603 M12x30 (6psc)</li> <li>b. 135DH 15.01.00 (1psc)</li> <li>c. ST0027.01 (6psc)</li> <li>d. Washer DIN 125 M12 (6psc)</li> <li>e. Nut DIN 985 M12 (6psc)</li> </ul>
---	---	------	-----------	--	---

**Table 9.5.1.2.** – components of front panel 135DH.15.01.00

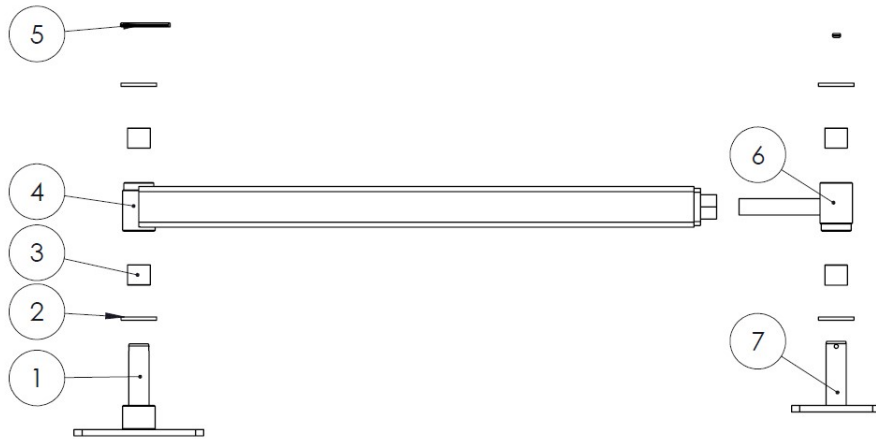


**Figure 9.5.1.3.** – components of right panel 135DH.15.03.00/ 165DH.15.03.00/ 195DH.15.03.00

Pos.	QTY	Part name	Part No	Assembly drawing	Components
1	1	Gluable seal	OT0036.01	10x20mm L=1225mm	
2	1	Sliding plate	135DH.15.00.04		g. Nut DIN 985 M8 (6psc) h. Washer DIN 125 M8 (6psc) i. 135DH.15.03.00 (1psc) j. 135DH.15.00.04 (1psc) k. Bolt DIN 603 M8x16 (6psc)

3	1	Side profile	135DH.15.09.00		<p>135DH.15.03.00:</p> <ul style="list-style-type: none"> <li>h. Bolt DIN 603 M10x40 (8psc)</li> <li>i. 135DH.15.03.00 (1psc)</li> <li>j. 135DH.15.09.00 (1psc)</li> <li>k. Washer DIN 125 M10 (8psc)</li> <li>l. Nut DIN 985 M10 (8psc)</li> </ul>
					<p>165DH.15.03.00:</p> <ul style="list-style-type: none"> <li>a. Bolt DIN 603 M10x40 (9psc)</li> <li>b. 165DH.15.03.00 (1psc)</li> <li>c. 165DH.15.09.00 (1psc)</li> <li>d. Washer DIN 125 M10 (9psc)</li> <li>e. Nut DIN 985 M10 (9psc)</li> </ul>
					<p>195DH.15.03.00:</p> <ul style="list-style-type: none"> <li>a. Bolt DIN 603 M10x40 (10psc)</li> <li>b. 195DH.15.03.00 (1psc)</li> <li>c. 195DH.15.09.00 (1psc)</li> <li>d. Washer DIN 125 M10 (10psc)</li> <li>e. Nut DIN 985 M10 (10psc)</li> </ul>
4	7	Plastic knob			<ul style="list-style-type: none"> <li>a. Nut DIN 985 M6 (1psc)</li> <li>b. Washer DIN 125 M6 (1psc)</li> <li>c. 135DH.15.03.00 (1psc)</li> <li>d. Plastic knob (1psc)</li> <li>e. Bolt DIN 933 M6x30 (1psc)</li> </ul>
5	1	Right panel	<p>135DH.15.02.00</p> <p>165DH.15.02.00</p> <p>195DH.15.02.00</p>		

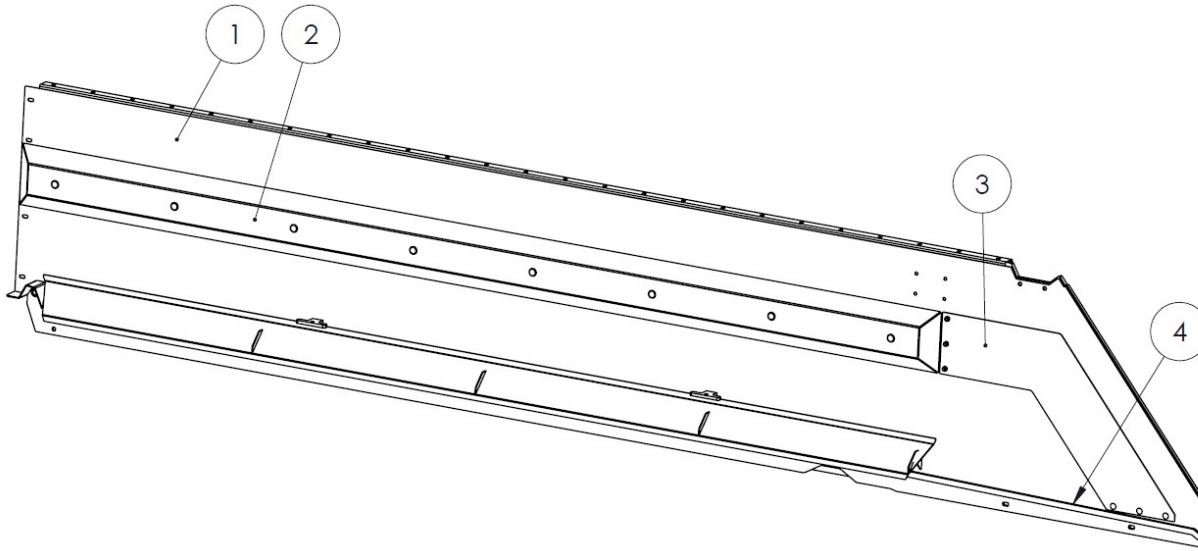
**Table 9.5.1.3.** – components of right panel 135DH.15.03.00



**Figure 9.5.1.4.** – components of lifting arm 135DH.15.10.00

Pos.	QTY	Part name	Part No	Description
1	1	Rear hatch axle ass.	135DH.15.16.00	
2	4	Washer	DIN 125	M24
3	4	Bushing Metal Backed	GSM-2528-25	d25_D28_L25
4	1	Lifting arm	135DH.15.10.00	
5	2	Splint pin	DIN 11023	D4,5
6	1	Threaded bushing	135DH.15.11.00	
7	1	Side wall axle ass.	135DH.15.14.00	

**Table 9.5.1.4.** – components of lifting arm 135DH.15.10.00



**Figure 9.5.1.5.** – components of left panel 135DH.15.02.00/ 165DH.15.02.00/ 195DH.15.02.00

Pos.	QTY	Part name	Part No	Assembly drawing	Components
1	1	Left panel	135DH.15.02.00		
2	1	Side profile	135DH.15.09.00		135DH.15.09.00 a. Bolt DIN 603 M10x40 (8psc) b. 135DH.15.03.00 (1psc) c. 135DH.15.09.00 (1psc) d. Washer DIN 125 M10 (8psc) Nut DIN 985 M10 (8psc)
					165DH.15.09.00 a. Bolt DIN 603 M10x40 (9psc) b. 135DH.15.03.00 (1psc) c. 135DH.15.09.00 (1psc) d. Washer DIN 125 M10 (9psc) e. Nut DIN 985 M10 (9psc)

					195DH.15.09.00 a. Bolt DIN 603 M10x40 (10psc) b. 135DH.15.03.00 (1psc) c. 135DH.15.09.00 (1psc) d. Washer DIN 125 M10 (10psc) e. Nut DIN 985 M10 (10psc)
3	1	Sliding plate	135DH.15.00.04		a. Nut DIN 985 M8 (6psc) b. Washer DIN 125 M8 (6psc) c. 135DH.15.03.00 (1psc) d. 135DH.15.00.04 (1psc) e. Bolt DIN 603 M8x16 (6psc)
4	1	Gluable seal	OT0036.01	10x20mm L=1225mm	

**Table 9.5.1.5.** – components of left panel 135DH.15.02.00

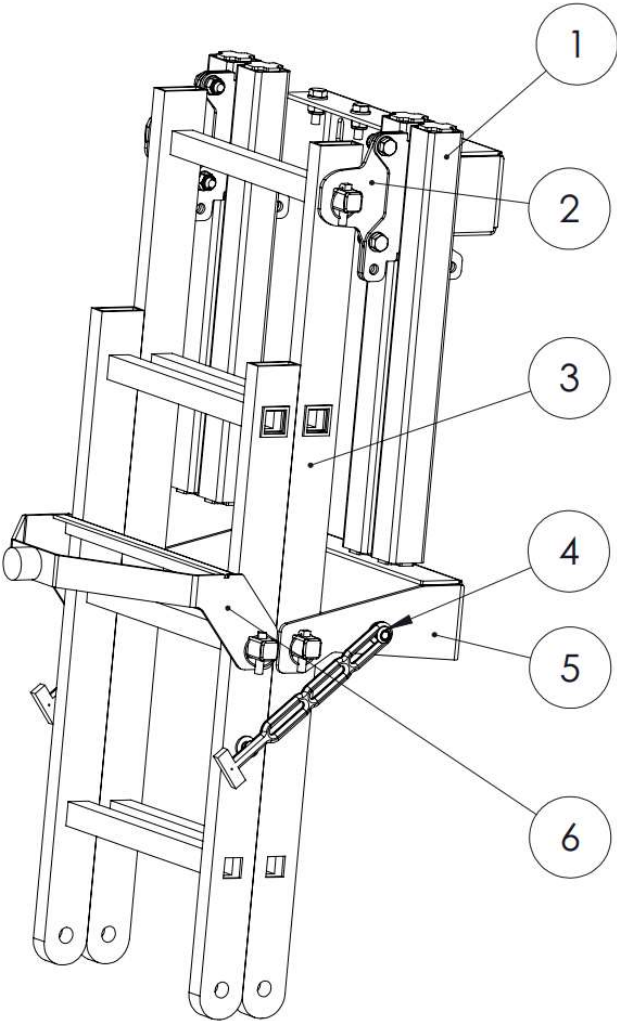
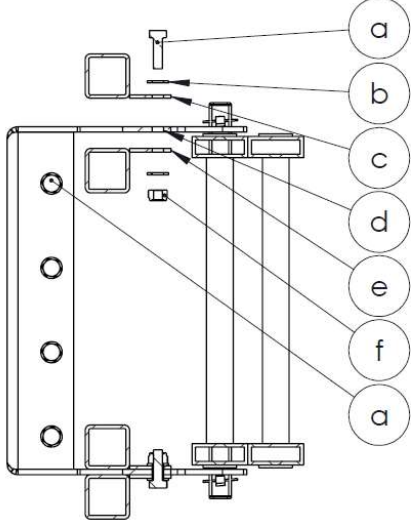
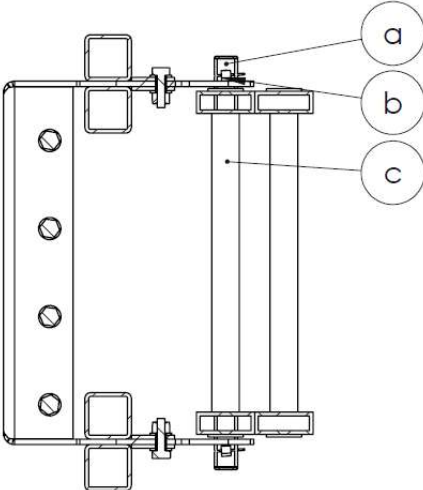


Figure 9.5.1.6. – components of ladder and support legs



Pos.	QTY	Part name	Part No	Assembly drawing	Components
1	1	Extension support legs	FE00.15.02.00	 An assembly drawing showing the installation of extension support legs. A vertical plate with four circular holes is being attached to a horizontal structure. Two vertical legs are being inserted into the plate. Callouts 'a' through 'f' point to various components: 'a' points to a bolt at the top of the legs, 'b' to a washer, 'c' to the left leg, 'd' to a splint pin, 'e' to the right leg, and 'f' to a nut at the bottom of the legs.	<ul style="list-style-type: none"><li>a. Bolt DIN 933 M12x30 (8psc)</li><li>b. Washer DIN 125 M12 (16psc)</li><li>c. FE00.15.02.00 left (2psc)</li><li>d. FE00.15.04.01 (1psc)</li><li>e. FE00.15.02.00 right (2psc)</li><li>f. Nut DIN 985 M12 (1psc)</li></ul>
2	1	Ladder top bracket	FE00.15.04.01	 An assembly drawing showing the installation of a ladder top bracket. A horizontal bracket is being attached to the top of the vertical plate. Callouts 'a' through 'd' point to components: 'a' points to a ladder fastening tube, 'b' to a splint pin, 'c' to a splint pin, and 'd' to the bracket itself.	<ul style="list-style-type: none"><li>a. Ladder fastening tube FE00.15.00.01 (1psc)</li><li>b. Splint pin DIN 11023 D11 (2psc)</li><li>c. OT0038.01 (1psc)</li><li>d. FE00.15.04.01 (1psc)</li></ul>

3	1	Foldable ladder	OT0038.01		
4	1	Plastic knob			<ul style="list-style-type: none"> <li>a. Nut DIN 985 M6 (2psc)</li> <li>b. Washer DIN 125 M6 (2psc)</li> <li>c. FE00.15.00.02 (1psc)</li> <li>d. Plastic knob (4psc)</li> <li>e. Rubber band (2psc)</li> <li>f. Bolt DIN 933 M6x30 (4psc)</li> <li>g. Rivet nut M6x18,5 (2psc)</li> <li>h. OT0038.01 (1psc)</li> </ul>
5	1	Ladder bottom bracket	FE00.15.00.02		<ul style="list-style-type: none"> <li>a. Ladder fastening tube FE00.15.00.01 (1psc)</li> <li>b. Splint pin DIN 11023 D11 (2psc)</li> <li>c. OT0038.01 (1psc)</li> <li>d. FE00.15.00.02 (1psc)</li> </ul>

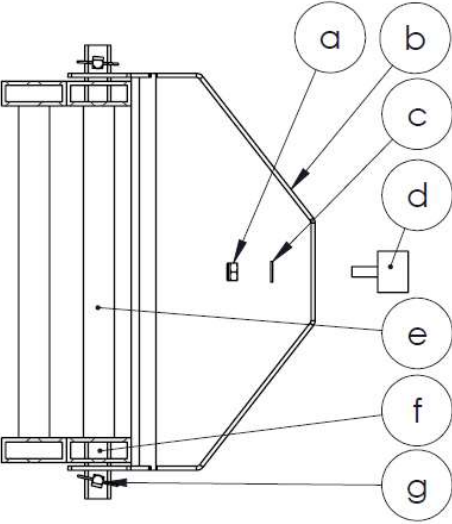
6	1	Ladder bottom support	FE00.15.08.00		<ul style="list-style-type: none"><li>a. Nut DIN 985 M10 (1psc)</li><li>b. FE00.15.08.00 (1psc)</li><li>c. Washer DIN 125 M10 (1psc)</li><li>d. OT0028.01 D40_L30_M10 (1psc)</li><li>e. OT0038.01 (1psc)</li><li>f. Ladder fastening tube FE00.15.00.01 (1psc)</li><li>g. Splint pin DIN 11023 D11 (2psc)</li></ul>
---	---	-----------------------	---------------	--	---

Table 9.5.1.6. – components of ladder and support legs

## 6. Extension assembling instruction 135DH/165DH

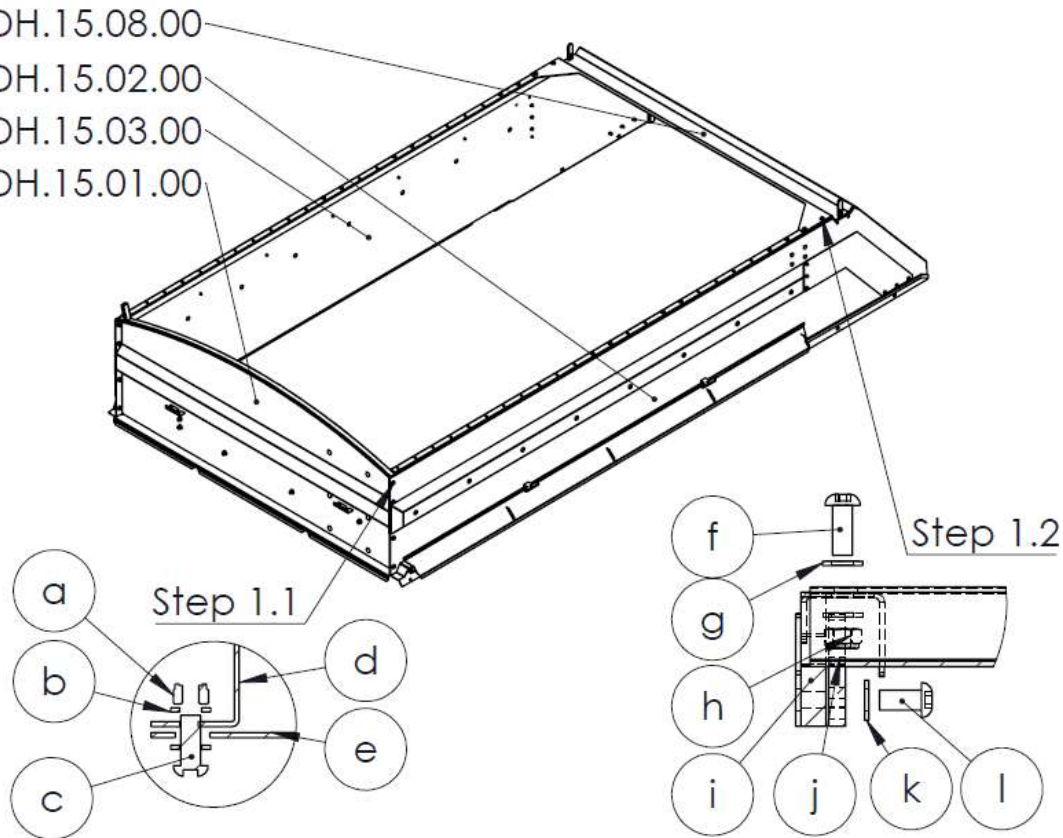
### 2. Step 1

135DH.15.08.00

135DH.15.02.00

135DH.15.03.00

135DH.15.01.00



Lift together 3 panels:

- 135DH.15.01.00 – front panel
- 135DH.15.02.00 – left panel
- 135DH.15.03.00 – right panel

Fasten the panels acc. to “step 1.1.” Leave bolts loose:

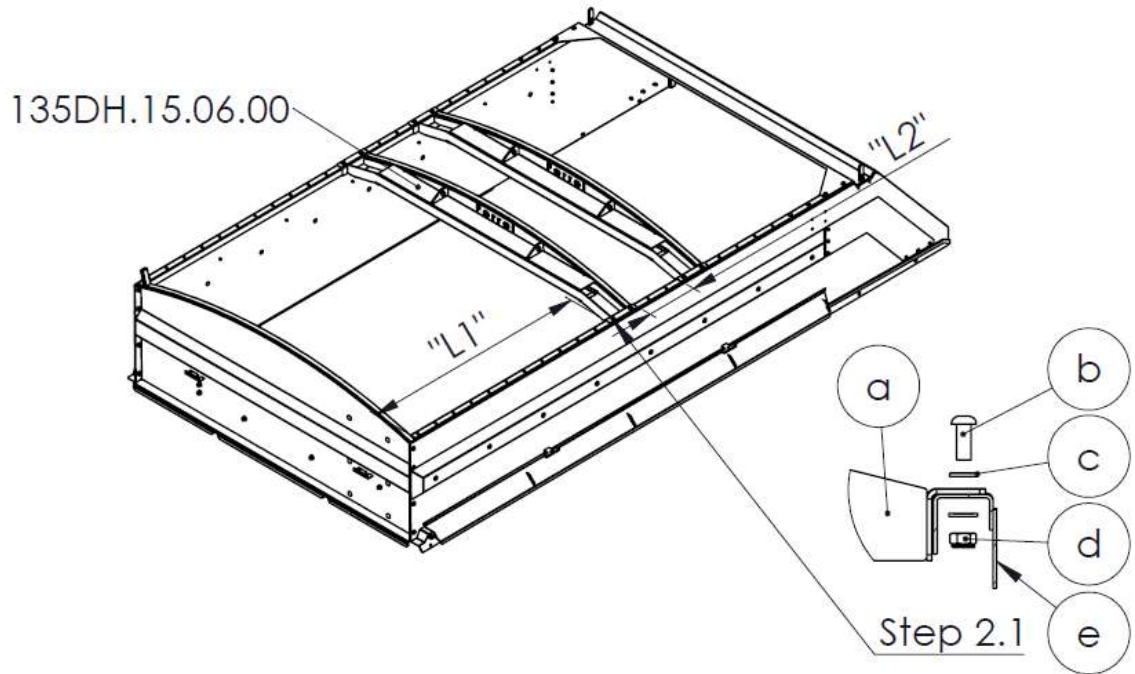
- a. Nut DIN 985 M10 (8psc)
- b. Washer DIN 125 M10 (16psc)
- c. Bolt DIN 7380 M10x30 (8psc)
- d. 135DH.15.01.00 – front panel
- e. 135DH.15.02.00 – left panel / 135DH.15.03.00 – right panel

Support the rear end with rear groove 135DH.15.08.00 acc. to “Step 1.2”:

- f. Bolt DIN 7380 M12x30 (4psc)
- g. Washer DIN 125 M12 (8psc)
- h. Nut DIN 985 M12 (4psc)
- i. 135DH.15.02.00 – left panel / 135DH.15.03.00 – right panel
- j. Rear groove 135DH.15.08.00
- k. Washer DIN 125 M12 (4psc)
- l. Bolt DIN 7380 M12x20 (4psc)

Figure 9.6.2.1. – Main assembly instructions step 1

3. Step 2



Add lifting beams 135DH.15.06.00 (2psc) onto assembly. Set distances L1 acc. to extension version:

135DH:

- L1 1650mm (12. Hole);
- L2 – Match to Your forklift.

165DH:

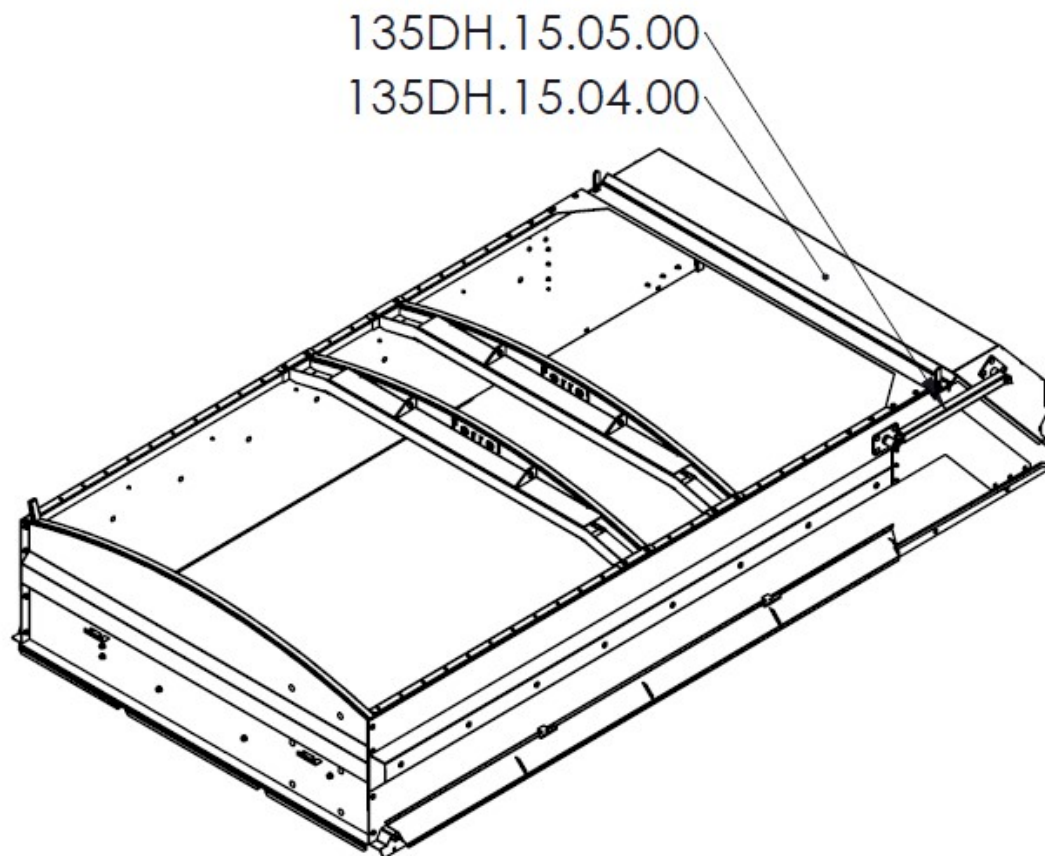
- L1 2050mm (14. Hole);
- L2 – Match to Your forklift.

Assemble to "step 2.1":

- lifting beams 135DH.15.06.00 (2psc)
- Bolt DIN 7380 M12x30 (4psc)
- Washer DIN 125 M12 (8psc)
- Nut DIN 985 M12 (4psc)
- 135DH.15.02.00 – left panel / 135DH.15.03.00 – right panel

Figure 9.6.2.2 – Main assembly instructions step 2

## 4. Step 3



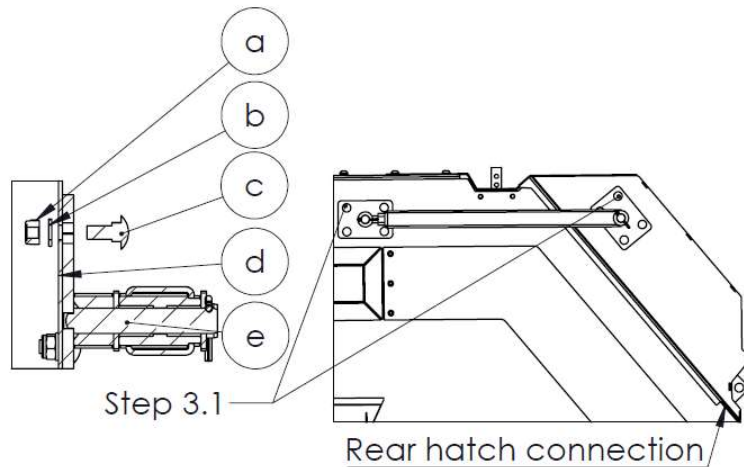
Lift Rear hatch 135DH.15.04.00 (1psc) onto the assembly. It shall rest on the extension without any additional support. At that state measure the Lifting arms 135DH.15.05.00 (2psc) – the lifting arms holes should match side panels holes and rear hatch holes without lifting the rear hatch. In order to match the lifting arm length – twist the lifting arm:

- Clockwise to reduce length
- Counterclockwise to add length.

Assemble the lift arms acc. to “step 3.1”:

- a- Nut DIN 985 M10 (16psc)
- b- Washer DIN 125 M10 (16psc)
- c- Bolt DIN 603 M10x25 (16psc)
- d- 135DH.15.04.00 (1psc)
- e- 135DH.15.05.00 (2psc)

After the assembly the connection between side panels and rear hatch should remain even on top and bottom.



**Figure 9.6.2.3. – Main assembly instructions step 3**

#### 5. Step 4

Prior of the lift:

- If You have front cover installed – turn it into lower position
- Remove 4psc DIN 912 bolts M12x50 (Step 4.2 a).

Lift extension unit onto the trailer. For lifting with chains use hooking points on lifting beams or slide forklift forks into the lifting beams. The forks must be minimum 1m long.

Fasten the extension unit:

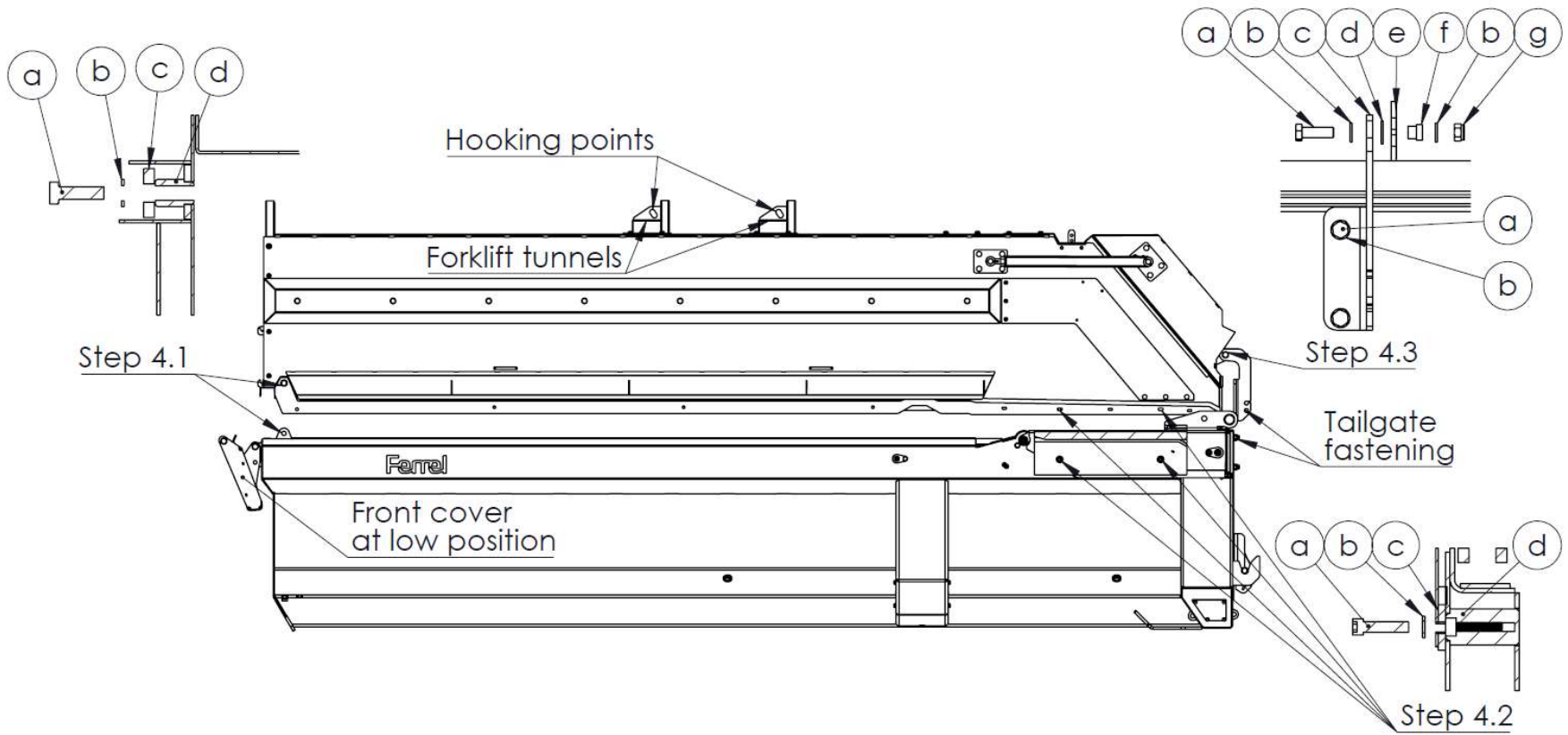


Figure 9.6.2.4. – Main assembly instructions step 4

Step 4.1:

- a- Bolt DIN 933 M16x50 (2psc)
- b- Washer DIN 125 M16 (2psc)
- c- DH trailer box
- d- Extension unit 135DH.15.00.00



Step 4.2

- a- Bolt DIN 933 M16x50 (6psc)
- b- Washer DIN 125 M16 (8psc)
- c- Tailgate fastening hinge 135DH.15.00.06 (2psc)
- d- Washer DIN 125 M20 (20psc)
- e- Extension rear hatch DH135.15.04.00
- f- Connection bushing 135DH.15.00.05 (2psc)
- g- Nut DIN 985 M16 (2psc)

Step 4.3

- a- Bolt DIN 912 M12x50 (4psc)
- b- Washer DIN 125 M12 (4psc)
- c- Extension unit 135DH.15.00.00
- d- DH box

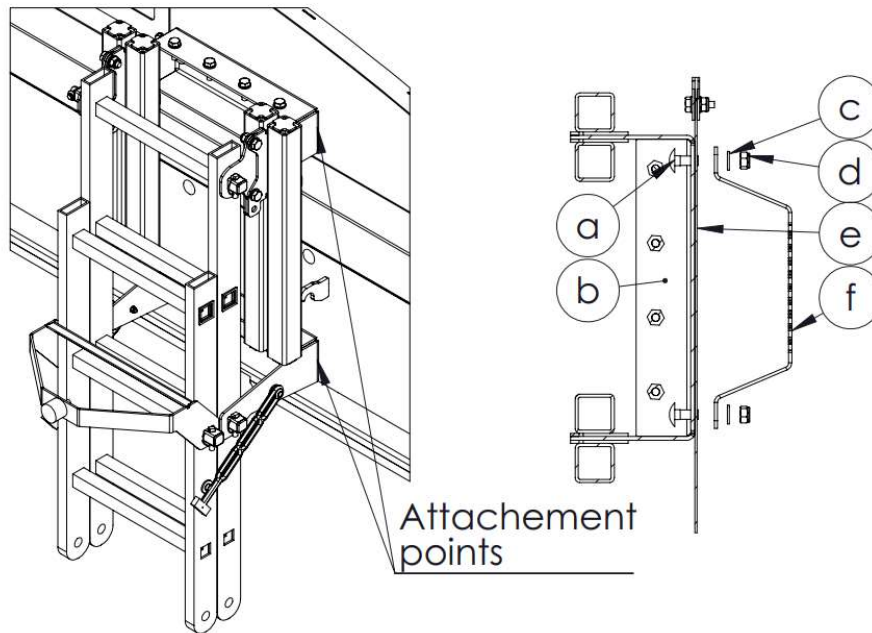
Fasten the bolts joining front panel to side panels (step 1.1)

In order to uninstall the extension, follow step 4 in reverse order.

## 7. Accessories

### 1. Ladder with support legs FE00.15.00.00

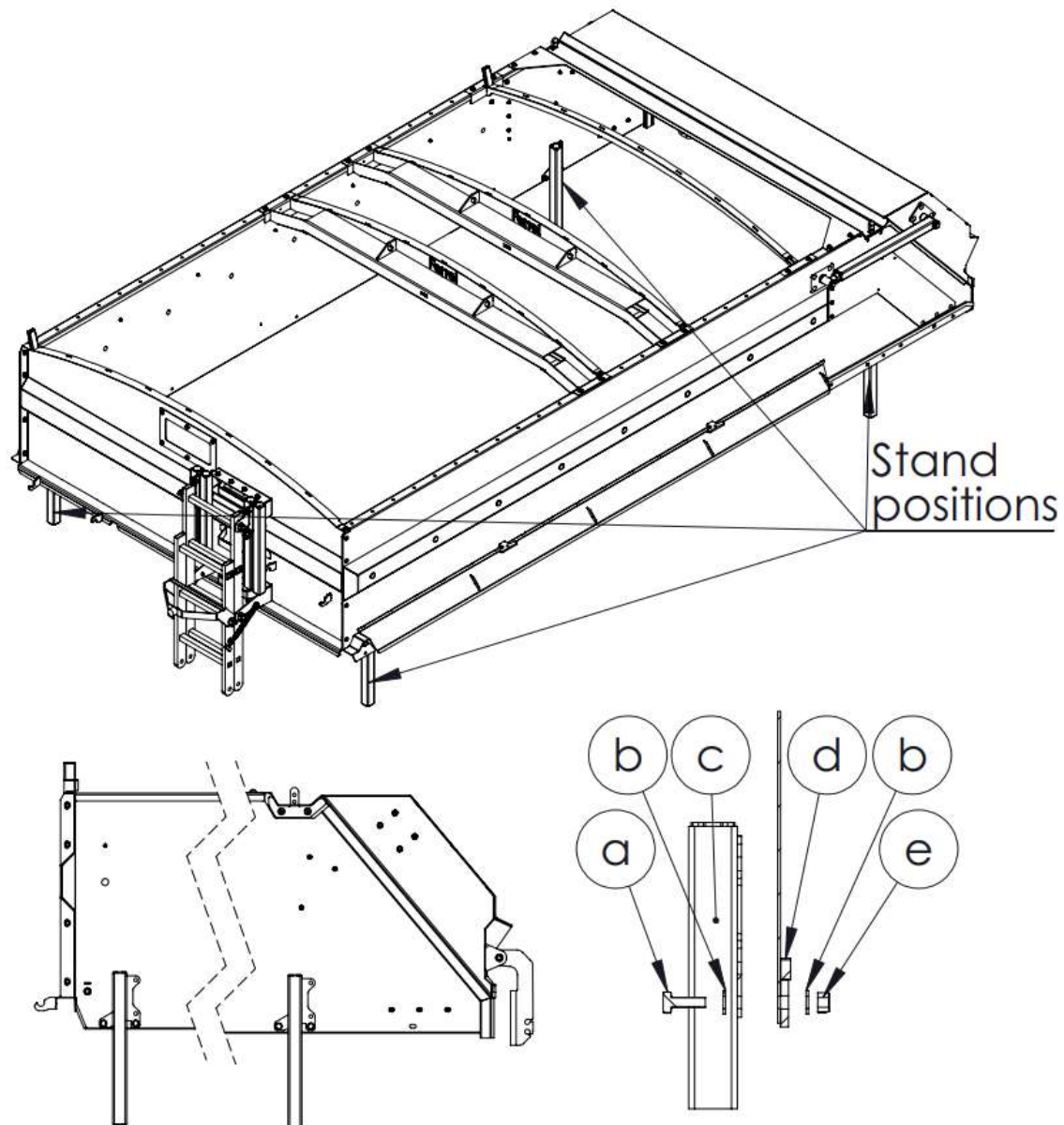
Support legs are used to keep the extension elevated while it is not installed on the trailer keeping it from rusting and keeping side skirt in shape.



Installation guide:

#### Figure 7.1.1. – Ladder installation guide

- Release the top and bottom step ST0027.01 (f) of the front panel.
- Reassemble the steps with ladder kit:
  - a- Bolt DIN 603 M12x30 (4psc)
  - b- Ladder kit FE00.15.00.00
  - c- Washer DIN 125 M12 (4psc)
  - d- Nut DIN 985 M12 (4psc)
  - e- Front panel 135DH.15.01.00
  - f- Step ST0027.01 (2psc)



**Figure 7.1.2.** – Support leg installation guide

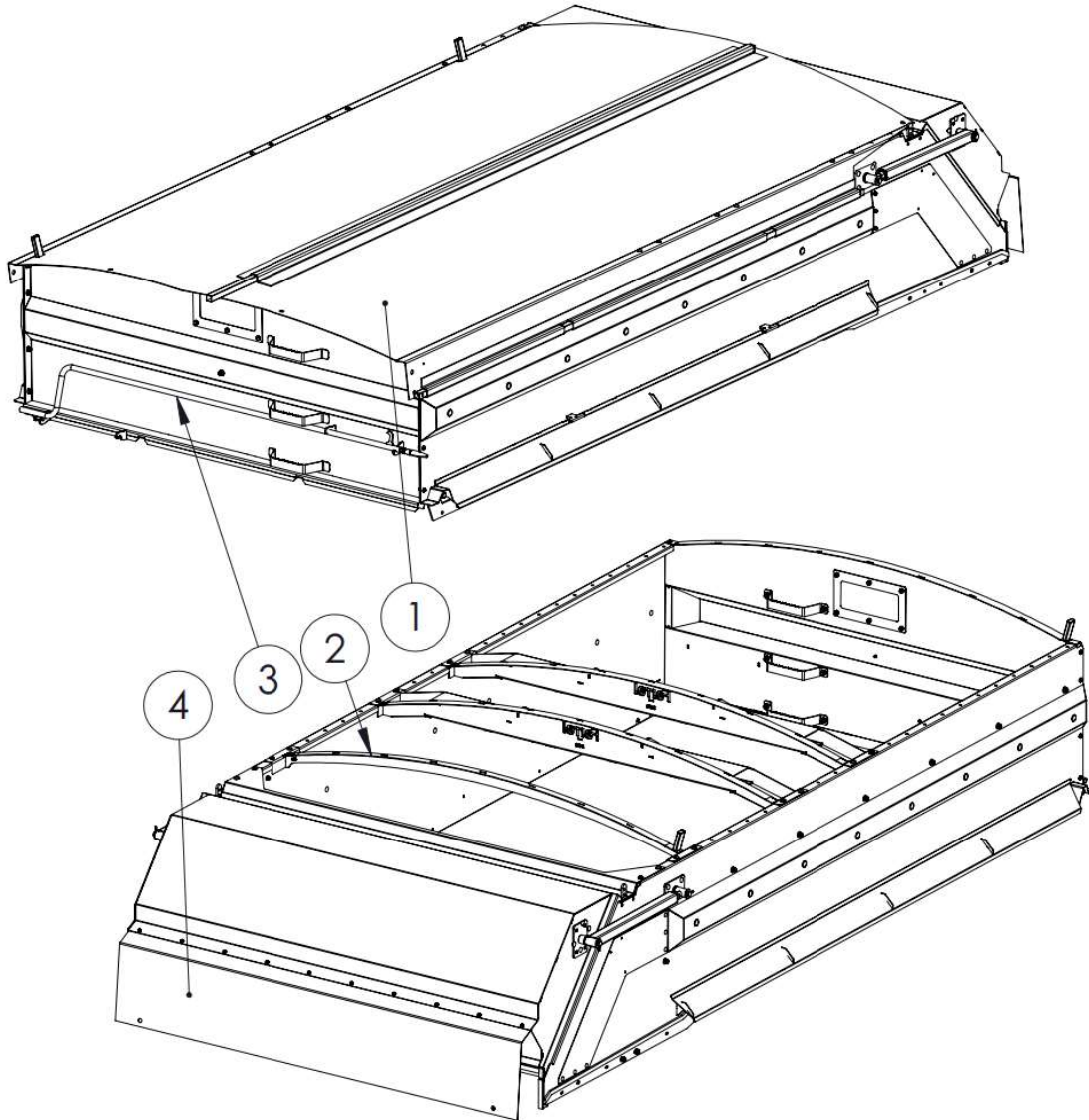
There are two different stands – left and right hand. Total set is 4 stands.

- a. Bolt DIN 933 M12x30 (4psc)
- b. Washer DIN 125 M12 (8psc)
- c. Support leg (4psc)
- d. Side panel
- e. Nut DIN 985 M12 (4psc)

## 8. Sheeting

Ferrel DH extension has a specific sheeting that to keep Your cargo dry whilst enabling to use the back door. The sheeting consists of 2 parts: main and back cover whilst back part is common for all DH extension versions. The sheeting is designed so that rear hatch can be operated with both main cover on and off.

### 1. Components of sheeting set



**Figure 8.1.1.** Components of DH extension sheeting set

Pos.	QTY	Part name	Part No
1	1	Main cover	135DH.15.15.00 165DH.15.15.00
2	1	Rear arc	135DH.15.07.00
3	1	Crank	135DH.15.20.00
4	1	Rear cover	OT135DH.15.04

**Table 8.1.1.** Components of DH extension sheeting set

## 2. Components of main cover

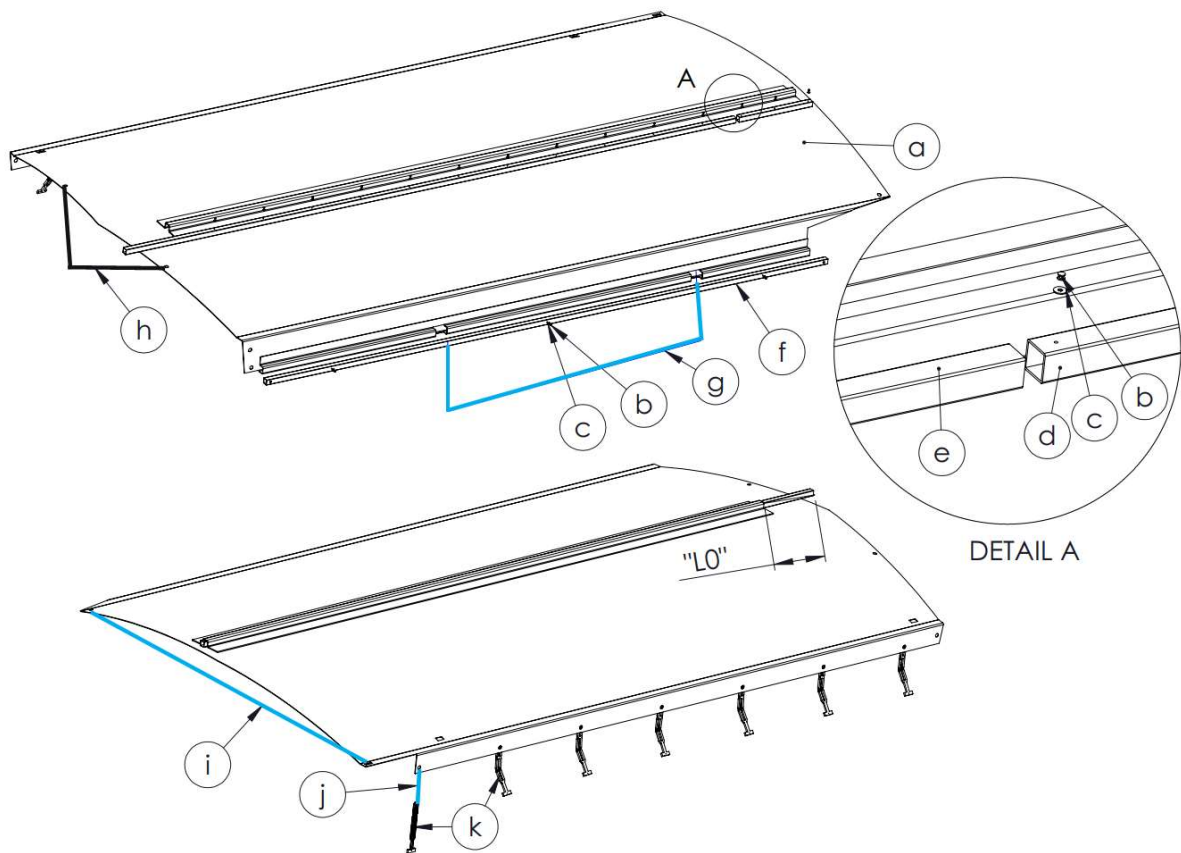


Figure 8.2.1 Components of DH extension main cover

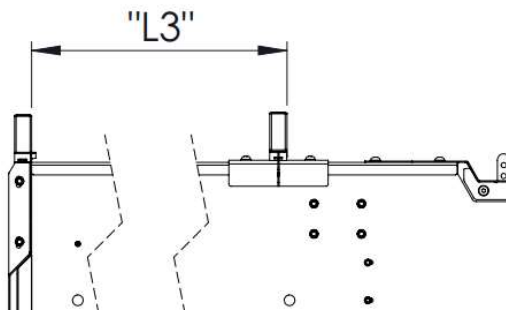
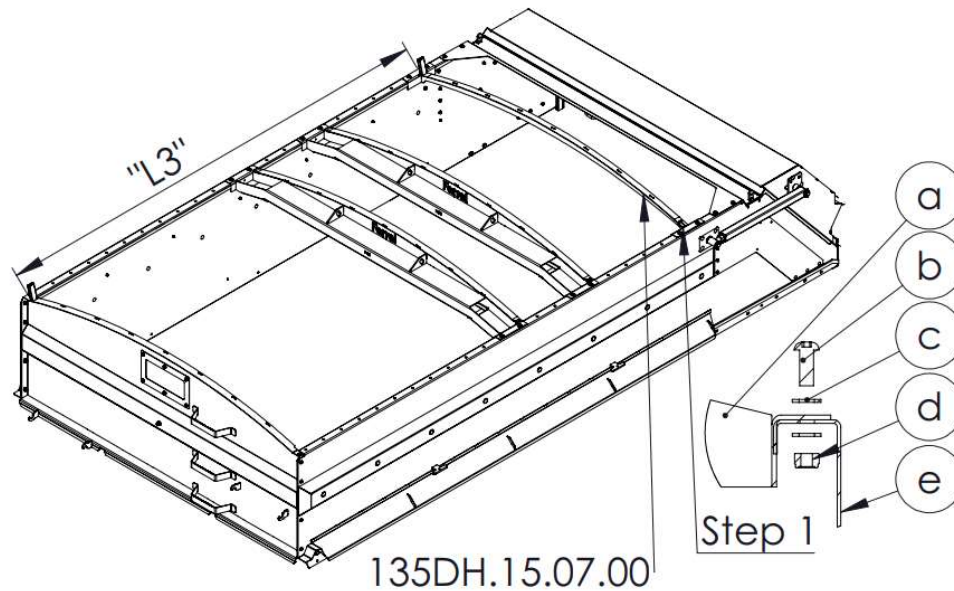
Pos.	Part name	Cover for 135DH		Cover for 165DH		Cover for 195DH	
		QTY	Part No	QTY	Part No	QTY	Part No
a	Main cover	1	135DH.15.15.00	1	165DH.15.15.00	1	195DH.15.15.00
b	Pull rivet	17	D3,2x6	19	D3,2x6	21	D3,2x6
c	Washer	17	DIN 9021 M4	19	DIN 9021 M4	21	DIN 9021 M4
d	Tail pipe	1	135DH.15.15.05	1	135DH.15.15.05	1	135DH.15.15.05
e	Rollup pipe	1	135DH.15.15.01	1	165DH.15.15.01	1	195DH.15.15.01
f	Pull pipe	1	135DH.15.15.06	1	165DH.15.15.06	1	195DH.15.15.06
g	Pull rope	8,5m	Rigid rope	8,5m	Rigid rope	8,5m	Rigid rope
h	Front rope	1m	Rubber rope	1m	Rubber rope	1m	Rubber rope
i	Leader rope	2,5m	Rigid rope	2,5m	Rigid rope	2,5m	Rigid rope
j	Extension rope	0,2m	Rigid rope	0,2m	Rigid rope	0,2m	Rigid rope

Table 8.2.1 Components of DH extension main cover

### 3. Cover installation guide

For better support, spread the lifting beams.

#### Step 1 – Rear arc



**Figure 8.3.1** – Rear arc installation

Install rear arc 135DH.15.07.00 (common for all DH extension versions):

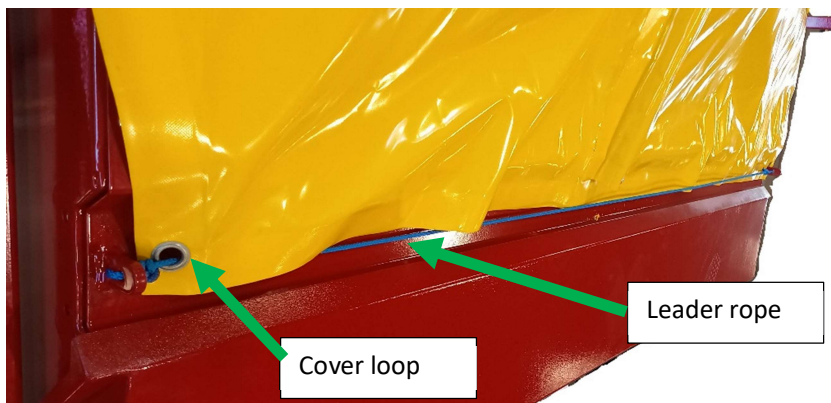
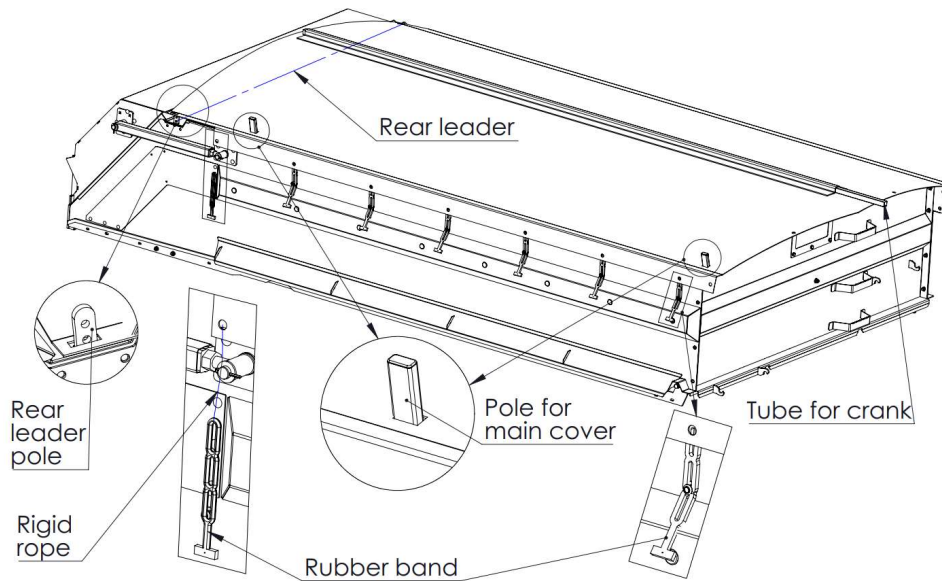
Install the rear arc into the last two holes before rear groove. Check the distance from front pole to rear arc pole:

- 135DH – L3 = 3,3m
- 165DH – L3 = 3,7m
- 195DH – L3 = 4,2m

Fasteners:

- i. Rear arc 135DH.15.07.00 (1pcs)
- ii. Bolt DIN 7380 M12x30 (4psc)
- iii. Washer DIN 125 M12 (8psc)
- iv. Nut DIN 985 M12 (4psc)
- v. Side panel

## Step 2 – Main cover



**Figure 8.3.2 – Main cover mounting**

Lift on the main cover.

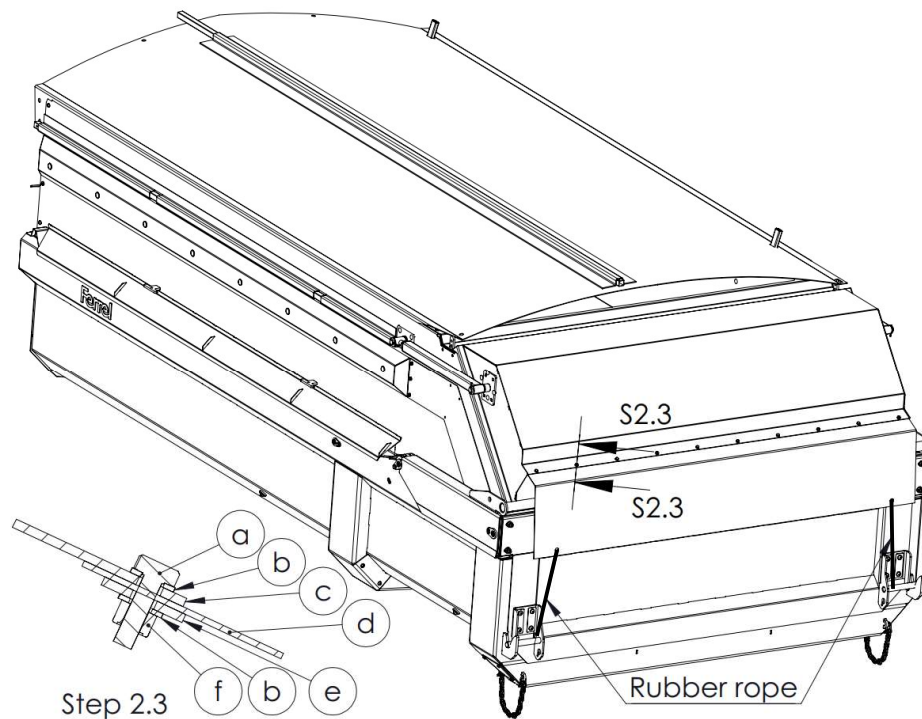
Ensure the cover is oriented correctly – the tube for crank extends to the front of the trailer.

The main cover has 3 square holes at the left side – 2 for poles will hold the cover in place. Rear will hold the leader rope.

Attach the rubber bands to the plastic knobs of right panel. Rear rubber band must be extended with 0,2m rigid rope. The rigid rope must go behind the rear hatch lifting arm.

Connect the rear leader – 2,5m rigid rope bind between two rear leader poles. The leader rope will go through the left rear end cover loop.

Leader rope should be fastened tightly. Ensure the knots do not intersect the lifting arms trajectory.

*Step 3 - Rear cover***Figure 8.3.3-** Rear cover mounting

Rear cover is installed under the ledge of rear hatch (common for all DH extension versions).

Assembly guide:

- a- Bolt DIN 933 M8x25 (10pcs)
- b- Washer DIN 125 M8 (20pcs)
- c- Rear hatch
- d- Rear cover
- e- Support plate 135DH.15.15.04 (1pcs)
- f- Nut DIN985 M8 (10pcs)

Attach rubber ropes to the trailer box's locks

#### 4. Operation instructions

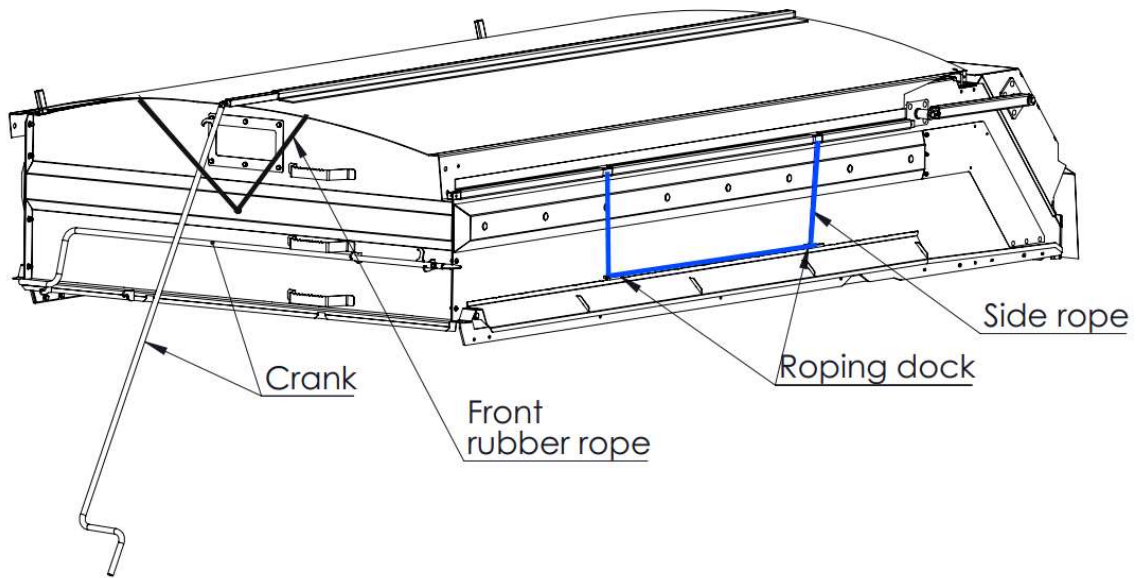
##### *Open cover*

- Unhook front rubber rope.
- Unwrap the rope from the left side.
- Take crank from the front panel and insert the flat end into hollow bar on top of the trailer.
- Wind the crank counterclockwise until cover is fully rolled up and against the side poles.
- Remove the crank and insert it back onto the front panel.

##### *Close cover*

- Pull from side ropes until side hollow bar drops down. (Note – both ropes must be pulled evenly and straight).
- Wind the side rope to roping dock.
- Hook the front rubber rope to plastic knob on front panel.





**Figure 8.3.4** – Open and close the main cover

## 10. WARRANTY CONDITIONS

The product warranty is valid for three year from the date of delivery or invoicing.

The warranty for following components of a trailer is one year:

- Towing bar
- Cylinders
- Rims and brakes
- Lights

Product warranty is valid only if:

1. The requirements specified in this manual have been adhered to;
2. The original parts are used for maintenance;
3. The maintenance is carried out by suitably qualified specialists;
4. The trailer has not been overloaded;
5. Hydraulic systems use normal pressure

Product warranty does not apply if damage is caused by incompetence and incorrect use of the product. The product warranty does not cover shipping costs and any loss of revenue due to any malfunction.

The manufacturer reserves the right to make changes without notice

**Manufacturer:**

Ferrel AS

Põllu 3,  
Sõmeru,  
Lääne-Virumaa,  
44201 ESTONIA

Phone +372 322 3421

Fax +372 322 3421

[sales@ferrel.ee](mailto:sales@ferrel.ee)

[www.ferrel.ee](http://www.ferrel.ee)